

Simulation Tools for Solar Cooling Systems – Comparison for a Virtual Chilled Water System

C. Bongs¹, A. Dalibard², P. Kohlenbach³, O. Marc⁴, I. Gurruchaga⁵, P. Tsekouras⁶

¹ Fraunhofer Institute for Solar Energy Systems (ISE), Heidenhofstraße 2, 79110 Freiburg, Germany, Phone: +49-761-4588-5487, Fax: +49-761-4588-9487, Email: constanze.bongs@ise.fraunhofer.de

² ZAFH.NET (Stuttgart University of Applied Sciences), Schellingstraße 24, 70174 Stuttgart, Germany

³ Solem Consulting, Postfach 2127, 71370 Weinstadt, Germany

⁴ Laboratory of Building Physics and Systems, University of Reunion Island, 40 av. de Soweto, 97410 Saint Pierre, France

⁵ AIGUASOL Engineering, Roger de Lluria 29, 3, 2, 08009 Barcelona, Spain

⁶ CRES - Centre for Renewable Energy Sources and Saving, 19th km Marathonos Av., Pikermi – 19009, Greece

Abstract

In the scope of the IEA Task 38 (Solar Air-Conditioning and Refrigeration) a comparative study of different simulation tools for solar cooling system pre-design was conducted. It aimed at identifying a range of uncertainties in simulation results which may be obtained by validated models from market available tools – and simulations performed by different experienced users. Tools applied in the simulation comparison comprise the fast pre-design tool EasyCool and the end-design tools TRNSYS, INSEL, SPARK and the TRNSYS-based TRANSOL. A model of a virtual office building in Palermo climate was used for the generation of a load file that was applied in all simulations. Further, a common system layout, component sizing and specifications, and a control strategy for the more advanced simulation tools were defined. The simulated solar cooling system is a chilled water system applying a 35kW absorption chiller by Yazaki (WFC 10). Results show that a margin of around 6 % deviation of the thermal performance parameters from their mean seems the best possible in the cross-comparison of the three closest baseline simulations – however the upper margin of around 20 % observed for all simulations may be more close to the real margin of variation. This reflects the high uncertainty in results of pre-design simulations and underlines the need of a good technical understanding by the user of simulation tools.

1. Introduction

Simulation in solar cooling and air-conditioning is possible at different levels. A classification of simulation levels may be made by distinguishing between material level, component level and system level. System simulations may generally be classified into (a) detailed system simulation for optimising control strategies and (b) system simulation for planning support which was the background for the study. The objective of the latter is to identify an appropriate system configuration and size with respect to fulfil target values in primary energy savings, solar thermal system exploitation and economics. The (a priori) design of a solar cooling system is a situation in which the performance of the system is not yet known. The decision to implement a certain design is often taken with the help of simulation studies. In that respect, the premises are similar to a virtual case study as presented here.

Generally, a number of different tools allowing different level of detail may be applied. The fast pre-design tool EasyCool and the more widely spread tools TRNSYS, INSEL, SPARK and the TRNSYS-based TRANSOL were used here.

2. Methodology

The comparative study focuses on the simulation of a chilled water system. In a preparatory step, a building was defined for this application. A load file generated with Palermo meteo data and characterised by high cooling loads was the common input to all simulations. A common system configuration and system sizing as well as a common control strategy were then defined. Parallel to the simulation of the solar cooling systems a reference system consisting of a compression chiller and a gas heater for winter operation were simulated in Easycool and TRNSYS. Only these two simulation tools, representing the categories of pre-design and advanced design tools, were used in the reference system simulation due to the simplicity of the calculations, using a constant efficiency method. The results of the different simulations were then compared with respect to energy related performance criteria, such as the specific collector yield, the solar fraction for cooling and the electricity consumption, allowing to estimate primary energy savings.

2.1. Building load: Palermo office building

The chosen reference object is a virtual two storey office building with additional basement. With the exception of the number of storeys, the building shell and geometry follow very closely the reference office building, designed within IEA-SHC Task 25 (Solar Air-Conditioning of Buildings) [1]. In comparison to the Task 25 office model, the peak cooling load is reduced to approximately 30 to 40 kW (depending on the location) and is thus more applicable for simulation with medium sized chiller systems. The building is oriented along the east-west axis with a total floor space of 930 m². Figure 1 shows the area specific monthly heating or cooling load and the specific global radiation on the collector area.

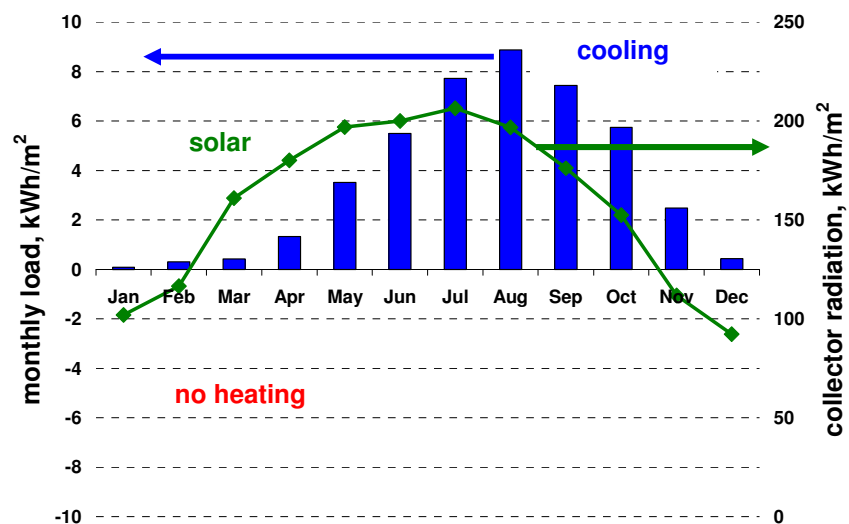

Figure 1: Monthly specific cooling load (left axis) and solar irradiation on collector surface (right axis) of the reference office building in Palermo

In the given Palermo load file, cooling loads are dominating. In winter, there is no significant heating share. The area specific cooling load reaches a maximum of 8.9 kWh/m² in August. The monthly collector radiation is very high in Palermo climate, with a maximum of 206 kWh/m² in July. On an accumulated monthly base, a quite good simultaneity between collector irradiation and building loads is given.

2.2. Chilled water system configuration

A common system configuration and system sizing were defined. The system configuration consists of a medium sized absorption chiller, a double-glazed flat plate collector field (115 m², SchücoSol U.5 DG), a hot buffer storage (3 m³) and a cold buffer storage (1.5 m³) and a cooling tower simulated with a constant temperature approach (constant cooling water supply temperature of 27 °C). As a first approach the 35kW Yazaki WFC 10 lithium bromide/ water absorption chiller model was applied in the simulations. A model of this chiller is available in SolAC, INSEL, TRNSYS [2] and TRANSSOL. EasyCool simulations were performed with a constant annual COP of 0.69. As no model of the 35kW Yazaki WFC10 chiller was available in SPARK, simulations were performed with a model of an absorption chiller in a similar capacity range, the 30 kW EAW absorption chiller. SPARK was therefore included in the simulation comparison, however results can only be assessed with respect to the order of magnitude. Cooling loads not covered by the absorption chiller are assumed to be covered by a conventional compression chiller assuming an annual COP of 3.5. Assumptions on electricity consumption were taken for each system component (cooling tower fans, pumps, absorption chiller).

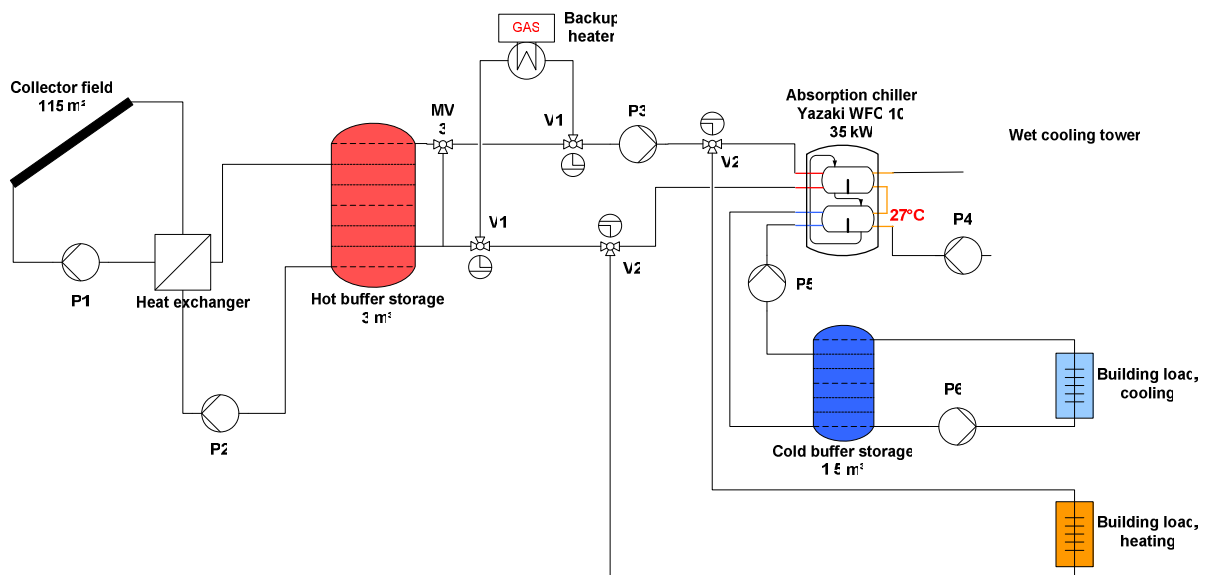

Figure 2: Schematic of Palermo system configuration for the baseline simulation

2.3. Energy related performance figures for simulation comparison

In order to compare the results of the different simulations, the following energy related performance criteria were defined.

- Net collector efficiency $= Q_{\text{coll_use}} / H_{\text{sol}}$ $\{0, \dots, 1\}$ or $\{0\% - 100\%\}$

This is the useful solar heat produced by the collectors $Q_{\text{coll_use}}$ which is delivered to the thermally driven chiller (cooling period) and the building heating (heating period), related to the radiation sum H_{sol} at the tilted collector aperture area. As building heating is hardly needed in the given load file, the main part of the useful solar heat is therefore the heat delivered to the thermally driven chiller.

- Specific collector yield $= Q_{\text{coll_use}} / A_{\text{coll}}$ $[\text{kWh/m}^2]$

This is the useful solar heat produced by the collectors $Q_{\text{coll_use}}$ in the considered evaluation period (heating or cooling period), related to the total collector area A_{coll} . In the case illustrated here, the specific collector yield relates to the cooling period.

- Solar fraction $= Q_{\text{coll_use}} / Q_{\text{heat_total}}$ $\{0, \dots, 1\}$ or $\{0\% - 100\%\}$

The solar fraction quantifies the solar coverage on the total heat requirements $Q_{\text{heat_total}}$ comprising both the heat for driving the thermally driven chiller (cooling period) and for building heating (heating period).

- Solar fraction cooling $= Q_{\text{cool_TD}} / Q_{\text{cool_total}}$ $\{0, \dots, 1\}$ or $\{0\% - 100\%\}$

The solar fraction cooling quantifies the share of useful cooling $Q_{\text{cool_TD}}$, produced by the thermally driven chiller and delivered to the building, to the total amount of cooling $Q_{\text{cool_total}}$ delivered to the building by both the thermally driven chiller and the backup compression chiller.

- Electricity consumption and use of the natural gas for backup heat source

This allows to calculate savings in primary energy and CO_2 emissions. In the case illustrated here, the backup heat source for heating is not needed. Therefore, primary energy savings are directly proportional to savings in electricity consumption.

3. Simulation comparison

The system configuration described in section 2.2. was simulated in all the different tools. The common system control strategy applied in the more detailed simulations can be found in [3]. Further simulations were performed with respect to a varied control strategy (variation of chiller starting temperature) and a varied size of the collector field. These simulations will not be discussed in this paper but can also be found in [3].

3.1. Results presentation: comparison of baseline simulation run

Results from the baseline simulation as described in section 2.2. are given in table 1.

Table 1: Key performance parameters of the baseline Palermo simulation results

	Mean (a,b,c) +/- Δ_{\max}	Mean tot +/- Δ_{\max}	INSEL (a)	EasyCool (b)	Transol (c)	SPARK (d)	TRNSYS (e)
$Q_{\text{coll_use}}$, [kWh/a] Useful collector heat	39623 +/- 6%	44068 +/- 21%	37250	39648	41971	48253	53218
$Q_{\text{cool_ACH}}$, [kWh/a] Cooling by thermal chiller	27244 +/- 6%	29039 +/- 11%	25865	26955	28911	31219	32244
$Q_{\text{cool_CCH}}$, [kWh/a] Cooling by compression chiller	13624 +/- 14%	11782 +/- 30%	15316	13813	11742	9534	8506
$\eta_{\text{coll_eff}}$, [-] Net collector efficiency	0.18 +/- 6%	0.20 +/- 21%	0.17	0.18	0.19	0.22	0.24
Specific collector yield [kWh/m ²]	345 +/- 6%	383 +/- 21%	324	345	365	420	463
Solar fraction cooling [-]	0.67 +/- 7%	0.69 +/- 14%	0.63	0.66	0.71	0.77	0.79
$W_{\text{el_backup}}$, [kWh _{el} /a] Electricity consumption compression chiller	3893 +/- 14%	3366 +/- 30%	4376	3947	3355	2724	2430
$W_{\text{el_tot}}$, [kWh _{el} /a] Total electricity consumption	7923 +/- 9%	7368 +/- 13%	7212	8353	8205	6595	6476

The simulation results can be classified into two groups (highlighted in grey and not highlighted). The first group of simulations with INSEL, EasyCool and TRANSOL (highlighted in grey) gave very similar simulation results. The deviation between the different simulations is around 6% on the thermal system parameters. The overall electricity consumption calculated by the different simulation tools varies by about 10%. The range of deviation is however higher when taking into account all simulations. Especially the useful collector heat is much higher in the TRNSYS and SPARK simulations, resulting also in a higher share of cooling provided by the thermal chiller and therefore significantly lower electricity consumption. The maximum range of deviation is around 20 % for the

solar thermal system parameters, but even higher when assessing the cooling provided by the backup compression chiller.

Table 2 gives the results of the Palermo simulation of the reference system. The deviations between the TRNSYS and EasyCool simulations are quite small – with a maximum range of 4 % concerning electricity consumption. The variation range decreases with the reduction in complexity of the simulated system.

Table 2: Simulation results of the Palermo reference system simulation

	EasyCool	TRNSYS
$Q_{\text{gas_backup}}$ [kWh/a]	10	9
Q_{cool} [kWh/a]	40750	40753
W_{el} [kWh _{el} /a]	12720	12188

3.2. Results interpretation – identification of differences between the simulations

From the presentation of the simulation results it is obvious that there is a significant range of variation. In order to understand the origin of these different results, the boundary conditions and assumptions of the different simulations will be discussed. Table 3 summarizes the differences in simulation settings. The main differences were found in the chiller model, the collector model and the assumed specifics of the control strategy.

Analysis of the results shows that the amount of used solar heat is a good indicator for the simulated thermal system performance. SPARK and TRNSYS simulations show the largest deviations from the mean of all simulations for all parameters. Here, the used solar heat gain is highest, giving a high share in cooling provided by the absorption chiller, high solar fraction and a resulting lower overall electricity consumption. The main reason for the larger deviation must mainly be found in the simulation of the solar system, as will be further explained below.

Although it was the aim to use an equivalent chiller model in all simulations, it turned out that an equivalent chiller model is simply not available for all the different tools. The TRNSYS and INSEL simulations use the characteristic equation model [4] for the chiller, but the parameter identification did not apply to the same Yazaki WFC10 chiller. The parameter identification of the TRNSYS model (type 177) referred to the “old” Yazaki chiller with bubble pump. For INSEL, the parameter identification referred to manufacturer data of the “new” Yazaki chiller with solution pump. In the INSEL model, the internal energy balances are solved for each time step as a function of the external entrance temperatures, so that changing mass flow rates can be considered in the model [5]. The performance data of the old chiller is not as good as the new one, especially for high hot water temperatures in the generator. This reflects in the higher average annual COP that is obtained in the INSEL simulations as compared to the TRNSYS simulations (baseline: 0.69 INSEL, 0.61 TRNSYS – not given in Table 3). TRANSOL uses a performance map model of the old Yazaki WFC10 chiller, reflecting manufacturer’s specifications. As mentioned before, the SPARK simulation uses a performance map of the 30 kW EAW chiller. EasyCool calculates chiller performance via a constant annual COP and is therefore the least detailed model.

Table 3: Identified differences in simulation setup of the particular contributions

	INSEL	EasyCool	TRANSOL	SPARK	TRNSYS
General: time step	6 min	1 h	0.5 h	10 min	10 min
Solar: radiation interpolation	No	No	Yes	Yes	No
Solar: collector thermal mass	Yes	No	Yes	No	No
Solar: stagnation modelled	Yes	No	Yes	No	No
Chiller: characteristic temperature ($\Delta\Delta T$) model	Yes	No	No	No	Yes
Chiller: performance map model	No	No	Yes	Yes, 30kW EAW	No
Chiller: constant COP model	No	Yes	No	No	No
Chiller: WFC10/ bubble pump	No	No	Yes	No	Yes
Chiller: WFC10/ solution pump	Yes	No	No	No	No
System: piping modelled	No	No	Yes	No	No
System: volume flow hot water to chiller	4.3 m ³ /h	No flow specified	8.6 m ³ /h	4.3 m ³ /h	4.3 m ³ /h
System: variable speed pumps for P3 in heating mode and P6	Yes	No	No	No	No
Control: Freezing protection in evaporator for the chiller mode	Yes	No	No	No	No

The main particularities of the single simulations can be summarized as follows.

TRNSYS: The TRNSYS results especially showed a high share in heat produced by the solar collectors. This reflects also in cold produced by the chillers and resulting high solar fractions. The collector was Type 1, which models the thermal performance of a flat-plate solar collector. The most likely reasons for the high solar fractions in the TRNSYS results are that stagnation is not taken account of and the collector thermal capacity is not included in the model.

SPARK: In SPARK simulations high solar fractions could be observed in comparison to the other simulation tools. These deviations probably originate from the solar collector model (simple efficiency model). Stagnation and thermal mass of collectors are not taken into account. Further reasons for this deviation might be the missing simulation of a heat exchanger between the primary and secondary solar loop and the application of a different chiller (30 kW EAW).

INSEL: The collector model is based on the Bengt Perers model [6]. It takes into account the thermal capacity of the collector (including water) and also optical calculations according to the different collectors (IAM factor in one direction for flat plate collector). The main differences in simulation

results originate from the more detailed control strategy. This includes taking account of collector stagnation and shutting down of the chiller when too much cold is produced (freezing protection).

TRANSOL: The collector model of TRANSOL is a new component which includes thermal capacity and several modes of operation, from fix flow to match flow driven by set temperature or constant temperature difference. The absorption machine is a standard component which reads performance data from an external file.

EasyCool: EasyCool is a simple pre-design tool, based on solving energy balances on an hourly basis. The collector model is a simple efficiency model and does not include the collector thermal mass. Collector stagnation and freezing protection of the chiller are not included, either. It can be observed that EasyCool simulations seem to slightly overestimate power consumption. This mainly originates from the simulation of constant speed pumps.

4. Summary and Conclusions

A general interpretation of the results of the cross-validation of different tools is quite difficult. The range of deviation between the different simulations is around approximately 6 % on the thermal system parameters for the three closest simulations. An overall range of deviation is found to be around 20 % for the thermal parameters. In terms of electricity consumption, differences in the range of +/- 10 % should be assumed. When looking at saved electricity - and therefore saved primary energy - the relative variations result much higher. Further result analysis shows that for the detailed system simulation applying the more advanced simulation tools, the simulation of the solar system is crucial. A more detailed system control including collector stagnation and chiller freezing protection seems to lead to significantly different results in comparison to simpler control strategies. It was also found that the chiller model for the Yazaki WFC10 implemented in the different tools is not equivalent. To achieve more detailed results all simulations should be validated against measured data which was not possible in the scope of this project. Therefore, the simulation study showed once more that a “plug-and-simulate” software for solar cooling is not available yet - all simulation packages require technical understanding of the system and a good understanding of models and their assumptions by the user.

References

- [1] Henning, H.-M. et al.(2007): Solar- Assisted Air- Conditioning in Buildings: A Handbook for Planners. Springer, Wien, New York.
- [2] Albers, J., 2002. Simulation des Teillastverhaltens von Absorptionskälteanlagen für die Solare Kälteerzeugung. In: Thermische Solarenergie, Tagungsband 12. OTTI-Symposium. pp. S. 246–250.
- [3] Bongs, C., et al.: Benchmarks for comparison of system simulation tools – Absorption chiller simulation comparison. IEA Task 38 - A technical report of subtask C, Novembre 2009.
- [4] Hellmann, H.-M., Schweigler, C., Ziegler, F.: The characteristic equation of sorption chillers. Proc. of the Int. Sorption Heat Pump Conf. (ISHPC 1999), Munich, 24.–26. March 1999; pp. 169–172.
- [5] Eicker, U., Pietruschka, D.: Design and performance of solar powered absorption cooling systems in office buildings. Energy and Buildings (2009), Volume 41, Issue 1, January 2009, pp. 81-91.
- [6] Perers, B., Bales, C.: “A Solar collector model for TRNSYS simulation and system testing” IEA SHC Task 26, Solar combisystems, Decembre 2002.