

Primary energy optimisation of a solar adsorption cooling plant through dynamic simulations

Antoine Dalibard*, Ursula Eicker

zafh.net - Centre of Applied Research Sustainable Energy Technologies

University of Applied Sciences Stuttgart, Schellingstr.24, 70174 Stuttgart, Germany

* Corresponding author: antoine.dalibard@hft-stuttgart.de, Tel +49 711 8926 2981

Abstract

This paper studies the primary energy optimisation potential of an existing large solar adsorption cooling plant (Festo company). This plant consists of 1218 m² (net area) vacuum tubes collectors, 2 hot storage tanks of 8.5 m³ each and 3 adsorption chillers of 350 kW cooling capacity each. Measurements and previous simulation studies show a good optimisation potential especially regarding the electricity consumption of the cooling towers [1]. The purpose of this paper is to quantify this potential in terms of primary energy savings by using dynamic simulations. The work focuses on the heat rejection loop which consists of the chillers and the cooling towers. Different control strategies of cooling towers fan speed are simulated. Additionally, different hydraulics configurations of the heat rejection loop with or without buffer storage tanks are studied in order to see the effect on the fan speed control of the cooling towers. The electrical COP of the global system can be increased up to 30-40% with such controls with a minor decrease in cooling capacity. The use of a buffer store between the chillers and the cooling towers is meaningful since it smoothes the temperature wave and makes the control easier and more stable. Specific primary energy savings up to 0.25 kWh_{PE}/kWh_{cooling} can be achieved with simple changes in the heat rejection loop.

Keywords: Adsorption, optimisation, heat rejection, simulation, primary energy.

1. Introduction

The solar adsorption cooling plant studied is an installation located in the vicinity of Stuttgart (Southern Germany). Measurement data analysis of the first two years of operation shows a quite low electrical performance of the system (electrical COP between 2.5 and 3.5) [1,5]. A large contribution of the electricity consumption is due to the cooling towers' fans which mostly run full speed even if the return cooling water temperature to the chillers is low. Furthermore, the temperature peaks due to adsorption/desorption cycle of the chillers make the control of the fans speed more difficult than for absorption chillers. The use of dynamic models is necessary to study the effect of control strategies and new hydraulics on the system performance. The simplified scheme of the installation is shown in figure 1. For this paper, only the heat rejection loop between the chillers and the cooling tower is considered for optimisation.

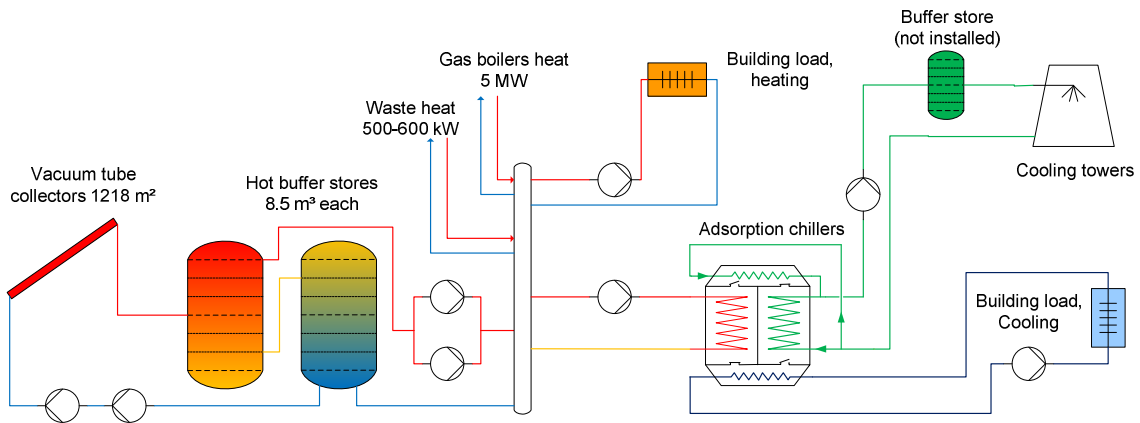

Fig. 1: Simplified hydraulic of the FESTO plant (buffer store not installed)

2. Modelling and validation

2.1. Adsorption chillers

The 3 chillers of the installation are silica gel/water adsorption chillers from Mayekawa (Type Mycom ADR100). A dynamic model has been implemented in the simulation environment INSEL [2,5]. The model is based on the work of Saha et al. [6] and has been improved using the approach of Wang [7] in order to describe better the dynamic of the cooling/heating fluids during the bed switching. Therefore an additional node has been used for the heat transfer fluids flowing in the adsorber, desorber, condenser and the evaporator. The silica-gel/water equilibrium model based on Henry's law equation derived by Ng [8] was used to describe the adsorption/desorption process. The model was compared with measurement data (in 10 seconds time interval) for different operating conditions (fig. 2,3).

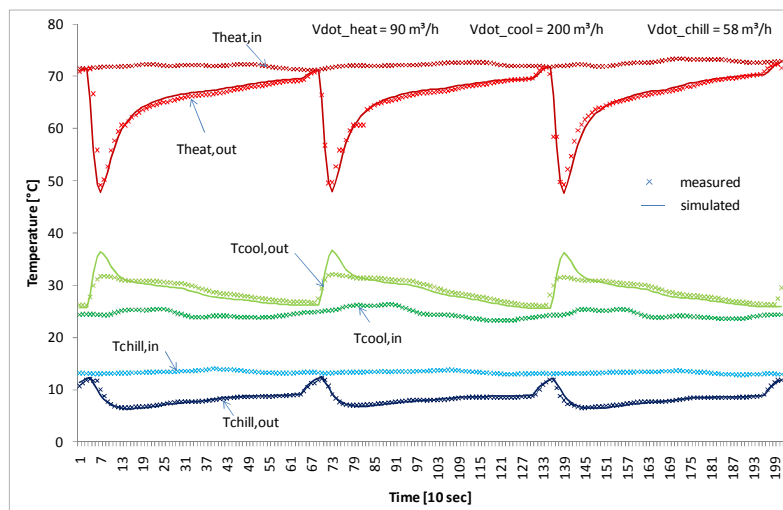

Fig. 2: Comparison measured / simulated values adsorption with nominal hot water flow rate

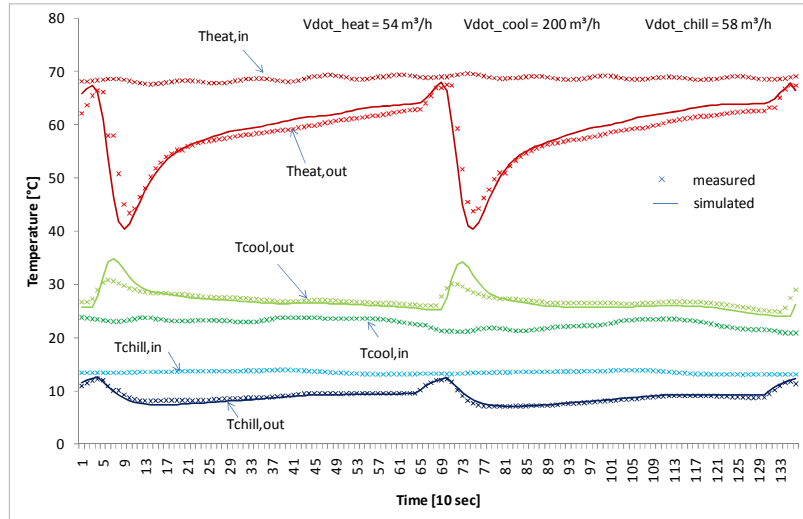

Fig. 3: Comparison measured / simulated values adsorption with reduced hot water flow rate

The results show good agreement between measured and simulated values. The error regarding the cooling capacity is in the range of 1-2% and the error regarding the COP is around 4-5%.

2.2. Wet closed cooling towers

For the heat rejection of the 3 chillers, the installation is equipped with 3 wet closed cooling towers from Baltimore (Type BAC VXI 215). The approach of Stabat [9] has been used for modelling the cooling tower. The parameters needed for the model have been fitted with measurement data. The model was compared for different operating conditions of the cooling tower: dry/wet regimes and different fan speed controls (fig.4, 5).

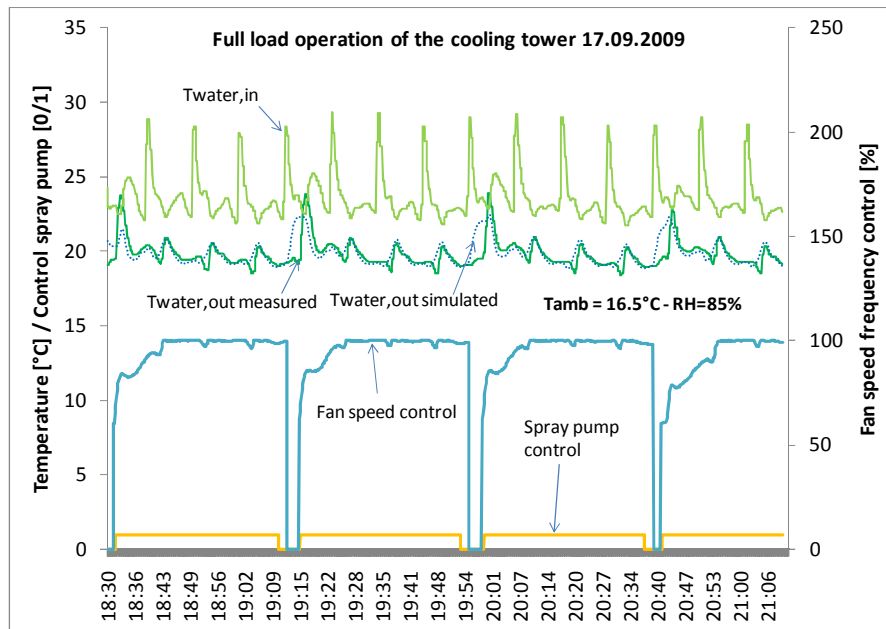

Fig.4: Full fan speed control of the cooling tower for dry and wet regimes

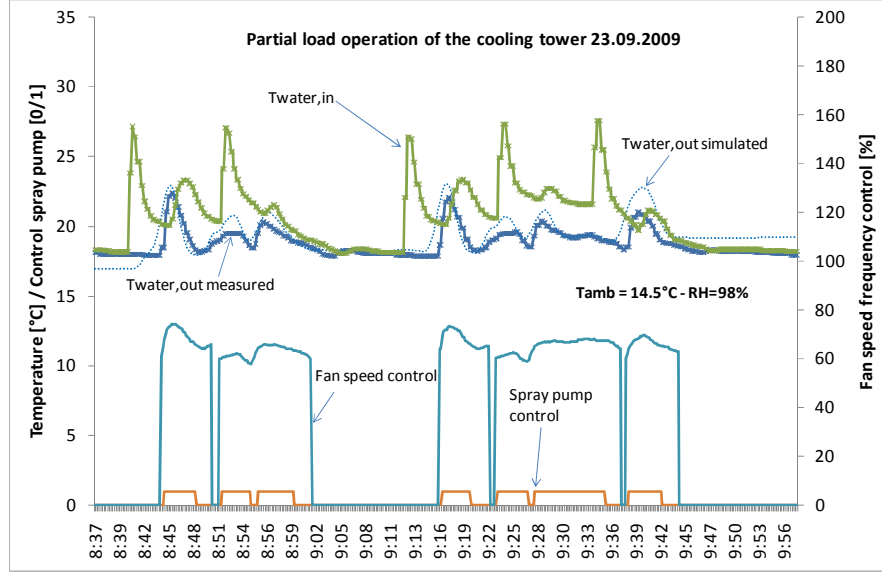

Fig.5: Reduced fan speed control of the cooling tower for dry and wet regimes

The results show good agreement between simulated and measured values. Nevertheless, it can be seen that when the cooling tower switch from dry to wet regime, it takes time until the heat exchanger is completely wet (or dry) which results in a time delay for the cooling effect. The model does not take into account this time constant. This explains the deviation between model and measurements when the spray pump starts (or stops). The electrical consumption of the fans is simulated with the affinity law (1) according to Cohen [10].

$$P_{elec,real} = P_{elec,nom} \left(\frac{\dot{v}_{air,real}}{\dot{v}_{air,nom}} \right)^3 \quad (1)$$

3. Methodology

3.1. Fan speed control

In order to show the optimisation potential in electricity reduction of the cooling towers, different control strategies of fan speed control have been simulated for one example morning from 8:00h until 12:00h (12th June 2010). During this period, only one chiller and one cooling tower were operated. The measured temperatures of inlet hot and chilled water are used as inputs in the model. Therefore, no interactions are considered between the chillers and these two loops. This approximation is justifiable since both loops have enough inertia to absorb the small temperature changes due to cooling tower control modifications. Table 1 shows the different cases simulated.

Table 1: Cases simulated for fan speed control

	Fan speed control	Spray pump control	Control explanation
Case 0	Reference (100%)	Reference (ON)	--
Case 1	Constant 80 %	Always ON	--
Case 2	Constant 50 %	Always ON	--
Case 3	Controlled with adsorption/desorption cycles	Always ON	100% when the temperature difference between outlet and inlet is higher than 6°C 60 % otherwise

Case 0 corresponds to the reference control that is currently implemented. This case has been simulated and compared with measurements (Table 2)

Table 2: Reference case

	Cooling energy (kWh)	Electrical consumption cooling tower (kWh)	Total electrical consumption of the system (kWh)	Thermal COP (-)	Electrical COP (-)	Mean cooling power (kW)
Measurement	895.1	184.7	307.9	0.51	2.91	231.3
Simulated	908.0	185.1	308.5	0.45	2.94	234.6

For simplicity, the total electricity consumption is estimated knowing that the cooling tower consumption represent around 60% of the total consumption [1]. Therefore, the electricity consumption of the rest of the system (everything excluding cooling towers) is calculated once for this period (123 kWh) and is assumed to be constant for the other cases.

3.2. Buffer store

Measurement data analysis shows that the batch operation of the adsorption chiller creates instability in the control of the cooling tower. Due to rapid temperature drop in the return water of the cooling tower, the set point temperature (around 19°C) is reached and both fan and spray pump are stopped. The control hysteresis makes that the cooling tower does not have enough cooling power to reject the heat when the next “hot water” wave comes (fig. 6). This results in an efficiency decrease of the chiller since the adsorber is actually heated instead of being cooled.

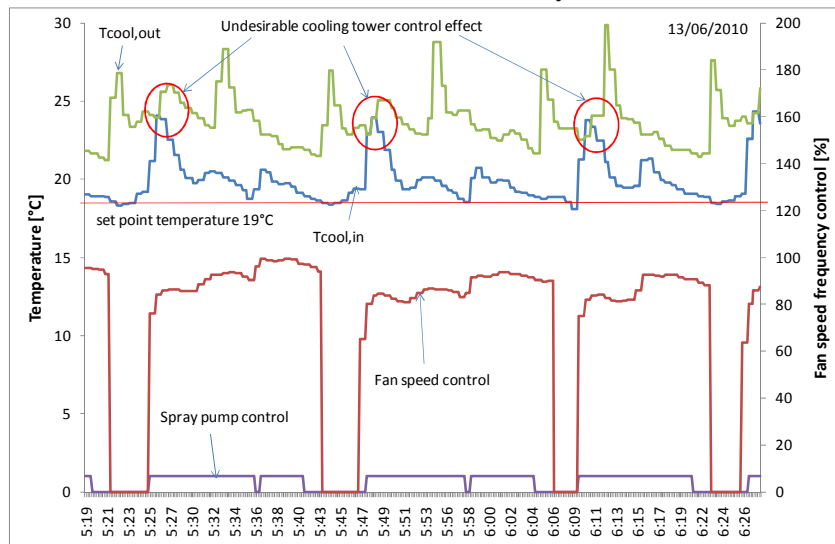

Fig 6: Undesirable cooling effect control effect due to adsorption/desorption cycle (measurements)

To avoid this problem by smoothing the temperature wave, a buffer store can be put between the outlet cooling water of the chiller and the cooling tower (fig.1). Again, different cases have been simulated for this period (13/06/2010) as shown in table 3.

Table 3: Simulated cases with buffer store

	Fan speed control	Spray pump control	Buffer store
Reference	Real	Real	No
Case a	Real	Real	Yes (1m ³)
Case b	Real	Real	Yes (5m ³)
Case c	Constant 75%	Always ON	No
Case d	Constant 75%	Always ON	Yes (5m ³)

4. Results and discussion

4.1. Fan speed control

The main results of the simulations are shown in figure 7 and table 4.

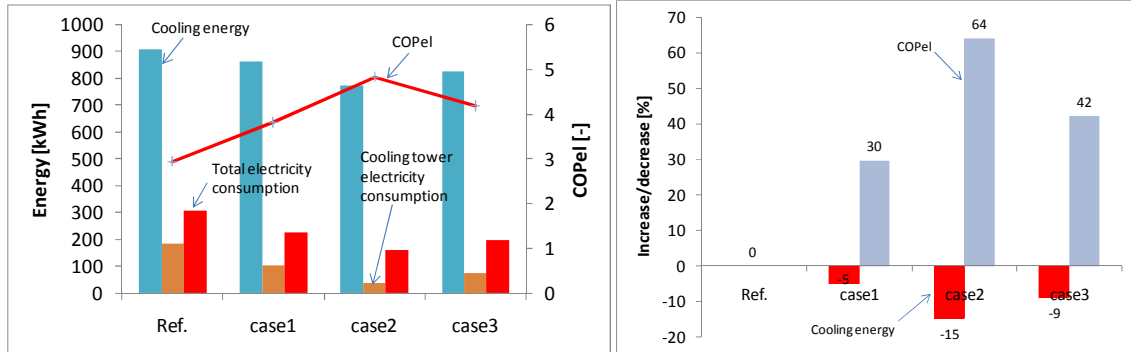

Fig. 7: Cooling energy produced and electrical performance for fan speed control

Table 4: Main results of the fan speed control simulation studies

	Cooling energy produced (kWh)	Electrical consumption due to cooling tower (kWh)	Total electrical consumption (kWh)	Electrical COP (-)	Chiller thermal COP (-)	Mean cooling power (kW)	Mean inlet cooling temperature (°C)
Ref	908.0	185.1	308.5	2.9	0.45	234.6	21.2
Case 1	862.4	102.6	226.0	3.8	0.44	222.9	22.0
Case 2	773.3	36.8	160.1	4.8	0.42	199.9	23.4
Case 3	826.0	74.1	197.5	4.2	0.44	213.5	22.6

The results show that reducing the fan speed by only 20% lead to an increase of the electrical COP of around 30% without reducing much the cooling capacity (5%). A more advanced control of the fan speed based on the adsorption/desorption cycle can lead to an increase of the electrical COP of above 40%. Of course, this has to be paid by a decrease of the cooling energy produced (9%). In order to increase the cooling capacity, it is better, from an energetic point of view, to increase the flow rate or the temperature of the hot water side (if solar or waster heat is available) than increase the fan speed.

4.2. Buffer store

The main results of the simulations are shown in figure 8 and table 5. Figure 9 shows the effect of the buffer (5m³) on the cooling temperatures by keeping the same cooling tower control (reference and case b).

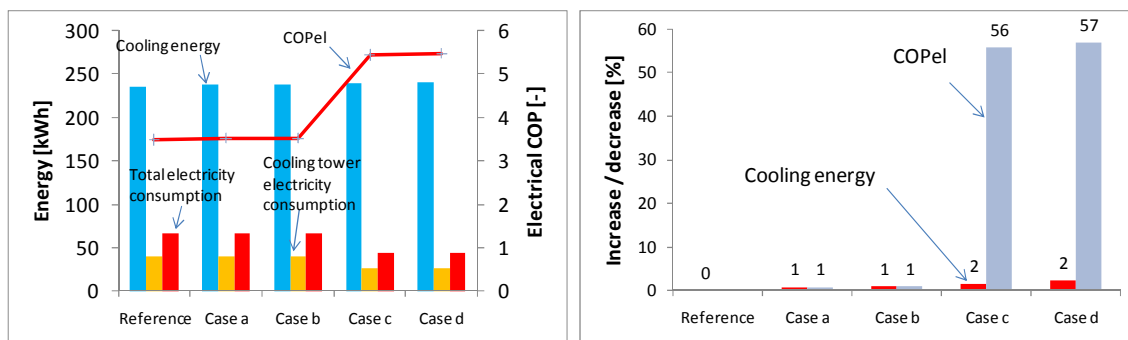

Fig. 8: Cooling energy produced and electrical performance for buffer store

Table 5: Main results of the buffer store simulation studies

	Cooling energy produced (kWh)	Electrical consumption due to cooling tower (kWh)	Total electrical consumption (kWh)	Electrical COP (-)	Chiller thermal COP (-)	Mean cooling power (kW)	Mean inlet cooling temperature (°C)
Ref	235.3	40.4	67.4	3.49	0.41	201.2	20.9
Case a	237.4	40.4	67.4	3.52	0.41	203.0	20.8
Case b	237.7	40.4	67.4	3.53	0.41	203.3	20.8
Case c	239.1	26.4	44.0	5.4	0.41	204.5	20.7
Case d	240.8	26.4	44.0	5.5	0.41	205.9	20.7

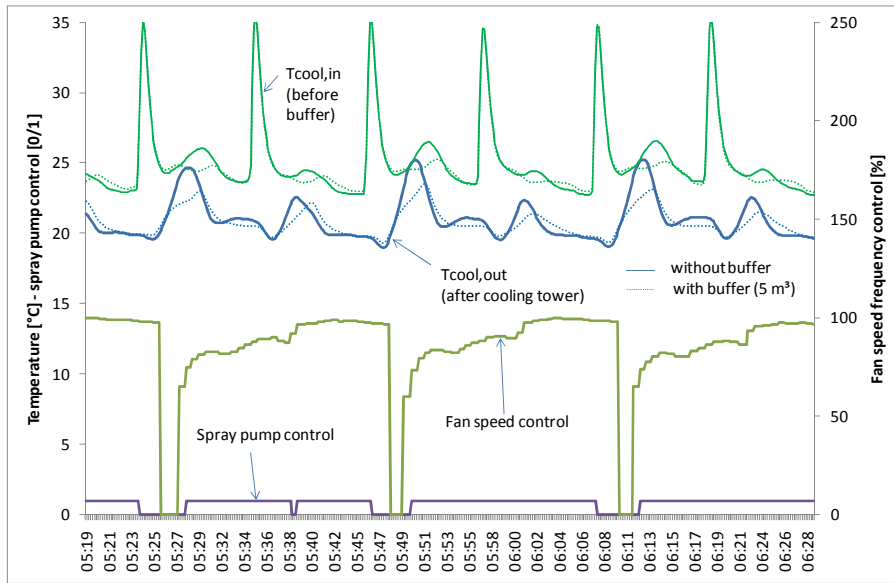

Fig. 9: Effect of the buffer store (5 m³) on the cooling temperature

The use of a buffer store does not improve the global performance significantly but it smoothes the temperature fluctuation which makes more stable both chiller operation and control of the cooling tower. Then a simple control (constant fan speed) allows to increase both chiller performance and reduce the electricity consumption (case d).

5. Primary energy savings

For each case, knowing the electricity savings, the specific primary energy savings can be calculated. Using the primary energy factor for electricity mix of Europe/Germany (generally 2.4 kWh_{PE} / kWh_{el}), the specific primary energy savings can be deduced (fig.10)

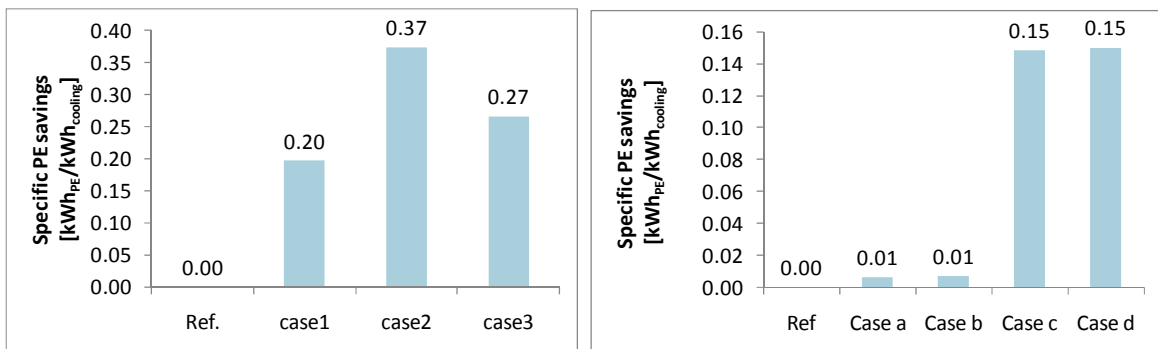

Fig. 10: Specific primary energy savings for different simulated cases

6. Conclusions

High electricity consumption due to heat rejection is a common problem for solar cooling plants. A good control of the cooling tower (fan speed) is essential in order to achieve primary energy savings. Closed adsorption cooling requires a special care since the batch operation of the chiller maybe causes instability of the heat rejection control which can lead to a decrease of the chiller performance as well as an increase in electricity consumption. The practical example of the Festo plant shows that the electrical COP can be increased up to 30-40% by paying attention to the cooling tower control and this with a minor decrease in cooling capacity. A buffer store between the chiller and the cooling tower can be used for a more stable chiller operation and an easier heat rejection control. Specific primary energy savings up to $0.25 \text{ kWh}_{\text{PE}}/\text{kWh}_{\text{cooling}}$ can be achieved.

7. Acknowledgments

This work would not have been possible without the collaboration of the company FESTO AG and the University of Applied Sciences Offenburg who have provided all the measurement data necessary for this study. This work has been supported by the 6th European Union Research Program's Marie-Curie early stage research training network in "Advanced solar heating and cooling for buildings" - SOLNET. <http://cms.uni-kassel.de/index.php?id=2142>



References:

- [1] A. Dalibard, D. Pietruschka, A. Biesinger, U. Eicker. „Optimisation potential of a large solar adsorption cooling plant“, *3rd International Conference in Solar Air Conditioning*, Palermo, Italy, 2009.
- [2] A. Dalibard, D. Pietruschka, U. Eicker, J. Schumacher. “Simulation of a large solar adsorption cooling plant“, *Eurosun 2008*, Lisbon, Portugal.
- [3] K. Huber, E. Bollin, E. Scheck, D. Jödicke, E. Wiemken, J. Wewior, U. Eicker, D. Pietruschka, A. Dalibard, R. Meißner, C. Kettner. „Operation Analysis and Energy Evaluation of a Solar-thermal System Assisting the Air Conditioning of an Office/Administration Building“, *Renknow.net*, 2010. www.renknow.net
- [4] U. Eicker, D. Pietruschka, A. Dalibard, E. Duminil. „Energy and economic performance of solar cooling systems“, *3rd International Conference in Solar Air Conditioning*, Palermo, Italy, 2009.
- [5] Schumacher, J. “Digitale Simulation regenerativer elektrischer Energieversorgungssysteme”, Dissertation Universität Oldenburg, 1991 www.insel.eu
- [6] Saha, B.B. et al.: “Computer simulation of a silica gel–water adsorption refrigeration cycle—the influence of operating conditions of cooling output and COP” *ASHRAE Transactions* 13 (6) (1995) 348–355.
- [7] Wang, X., Chua H.T. “Two bed silica gel – water adsorption chillers: an effectual lumped parameter model”, *International Journal of Refrigeration* 30 (2007), 1417-1426.
- [8] K. C. Ng, H. T. Chua, C. Y. Chung, C. H. Loke, T. Kashiwagi, A. Akisawa, B. B. Saha. “Experimental investigation of the silica gel–water adsorption isotherm characteristics”, *Applied Thermal Engineering*, Volume 21, Issue 16, 2001, 1631-1642.
- [9] Stabat, P. & Marchio, D. “Simplified model for indirect-contact evaporative cooling-tower behaviour” *Applied Energy*, 2004, 78, 433-451
- [10] Cohen B. (Baltimore Aircoil), “Variable frequency drives: operation and application with evaporative cooling equipment”, *CTI Journal*, Vol.38, n°2, p. 28-31.