

LOW ENERGY CITY QUARTERS WITH HIGH RENEWABLE FRACTIONS: MONITORING RESULTS AND POTENTIAL FOR REPLICATION

Ursula Eicker¹, Aneta Strzalka¹, Tobias Erhart¹ and Jose Antonio Perrella Balestieri²

¹ *University of Applied Sciences Stuttgart, Schellingstr. 24, 70174 Stuttgart, Germany.*

email : ursula.eicker@hft-stuttgart.de

² *Univ Estadual Paulista, Av. Ariberto P. Cunha, 333, 12516-410, Guaratinguetá, SP, Brazil*

ABSTRACT

The paper presents monitoring results from the implementation of energy efficient buildings, renewable energy supply systems and energy management in a sustainable neighbourhood in Germany. The whole quarter has low energy standard buildings, which have been monitored for heating and electricity consumption. About 80% of the heating energy demand and 50% of the electricity consumption of the whole area is supplied by a wood fired co-generation plant with 1 MW electrical output and 5.3 MW thermal power output. In summer the heat from the network is used for decentralised absorption cooling in one of the office buildings. The main performance results of this monitored area are presented and the potential for replication are discussed.

Keywords: Energy efficient buildings, communal energy management, renewable energy supply

INTRODUCTION

Most countries have significantly and measurably increased their renewable energy fraction of electricity, but less so in the heat sector; however, the urban energy demand has not gone down significantly. Benchmarks are usually not available against which to measure the achieved CO₂ reduction. Energy consumption data are mostly available on a macroscopic scale (national or international) or on a microscopic scale (individual households), but rarely on a city scale.

Newman, 1982 [1] compared the energy consumption of Australian cities with other cities worldwide. The average Australian domestic energy consumption in urban areas was 14.8 GJ per capita not including transport, compared to 55.8 GJ in the United States and 29.7 GJ in Germany. Even when normalizing the heating and cooling energy consumption to degree days and square meters living space, substantial variations between 14 Wh m⁻² degree day⁻¹ for Australia and 70 Wh m⁻² degree day⁻¹ for the US in the early 1970s and between 17 (Australia) and 44 Wh m⁻² degree day⁻¹ for Germany in the mid-1990s were obtained [3], indicating the importance of other non-climate factors.

An analysis of different cities in India, Brazil and Australia showed that energy consumption increases with income, especially if indirect energy for goods and services is included [5]. At equal income levels, urbanized areas perform about 10% better than rural areas [2]. However, the urbanization most often accompanies increases in income. For example, in Japan, energy consumption in the residential sector has been increasing continuously due to rising standards of living, such as larger living spaces per person, an increase in number of small families or single households and more numerous home electric appliances. In the last 25 years, the energy consumption of the residential sector has doubled while the population growth was only 10% [4]. Compared to 1990, the CO₂ emissions from energy use in the residential sector have increased by 28.8% in 2002.

Detailed monitoring data from entire cities or neighbourhoods are rarely available, making it

difficult to separate the effects of building energy standards, user influence on energy consumption and other climate related issues. Furthermore, there is little knowledge on performance of local renewable energy supply systems such as biomass cogeneration plants, which creates barriers to a more wide spread use of the technology.

The paper discusses performance monitoring results of buildings constructed during the last decade and analyses the influence of building standard versus user behaviour. Furthermore, it reports on ORC (Organic-Rankine-Cycle) biomass technology which provides the main heating and electricity supply to the district. The transferability of the concepts suggested to other cities is also discussed.

1.1 The context of buildings sustainability

Incentives for sustainable buildings and cities are present in several countries. The focus varies largely. China, for example, is imposing new challenges in terms of sustainable energy supply to face its fast and accelerated development. Contributions due to the fast urbanization development and consequent problem of energy consumption [14], CO₂-emissions reduction by means of buildings energy efficiency [15] or discussion of indicators for assessing energy efficiency in buildings [16] come from there.

Brazil is another developing country in which sustainable energy is under discussion. As a part of its national energy plan 2030, the PNE2030, an energy efficiency national plan (PNEf) is prepared [23]. One of the considered sectors is related to buildings and presents actions to be implemented in medium term. Buildings certification is a reality in Brazil since 2010, when the National Institute of Metrology, Standardization and Industrial Quality (INMETRO, in Portuguese) defined the appropriated standards by means of Portaria 372 [26].

A brief review of the standards of Brazilian regulatory framework [26] shows that buildings must be evaluated according to three levels, envelope, illumination and air conditioning, with

weights of 30%, 30% and 40%, respectively; a final grade is obtained by the summation of the performance of a building in each of the three levels, multiplied by their corresponding weights, and a fourth variable, corresponding to an eventual available bonus. The grades vary from 0 to 5, being A from 4.5 to 5 and for the remaining grades it decreases one point until 1.5 or less, corresponding to the grade E.

Renewable energy systems or sources (photovoltaic panels or wind generators for producing electricity, solar collectors for producing hot water if solar fraction is higher than 70%), cogeneration systems or innovative lighting systems can also be added to the building design as a way to improve the final grade. The bonus varies from 0 to 1 and is attributed in the case of guaranteeing an energy economy by installing systems or equipment to reduce the water consumption.

There is an agreement (PL 630) under discussion since 2003 [24] that proposes the creation of a special fund for financing research and implementation of electric and thermal energy production by using solar and wind sources, with incentives to buildings for integration of solar panels and wind generators. In some cities, such as São Paulo, the Brazilian major city, municipal laws impose that every new public building under construction has solar panels for hot water production; it is also a reality in certain states, such as Rio de Janeiro for example.

A cogeneration framework is also well established in Brazil by Portaria 235 of National Agency of Electricity [6]; to qualify for support, it is necessary to satisfy two energy efficiency inequalities, one related to the thermal demand to fuel input ratio (it must be higher or equal than 15%) and the other to the thermal and electric demand to fuel input ratio. The last inequality considers three levels of power capacity (less than 5 MW, 5 to 20 MW and more than 20 MW) and the use of fossil or renewable sources – major incentives are for lower capacities burning renewable fuels.

1.2 The case study

The case study area analysed is located in the German town of Ostfildern at the southern perimeter of the city of Stuttgart and the neighbourhood investigated is the Scharnhauser Park. The area is a former military ground and has been developed since 1992. The area has 150 hectares and includes public spaces, 90 000 m² of commercial area and several housing types such as multifamily apartment blocks, row houses, public buildings and some single family homes. The project is part of a large European funding initiative named CONCERTO, which supports concepts for city neighbourhoods with high energy efficiency and renewable integration in 58 communities in Europe. The project discussed here is part of the POLYCITY project, which is coordinated by the authors from the University of Applied Sciences Stuttgart. All data discussed in the paper have been collected during the six years of the European project.

Fig. 1 shows the area of study with a general view of Scharnhauser Park and identifies buildings under consideration in this analysis: commercial buildings, detached houses, multi-family houses, renovated multi-family houses, tower blocks, town hall, school and biomass power plant. The heating and cooling loads as well as the electric energy consumption of these buildings were continuously monitored from 2005 to 2010. New buildings were constructed taking into account low energy standards, and the generation system that provides electric energy and district heating for the area is based on a cogeneration based on local biomass, an interesting alternative for reducing CO₂-emissions.

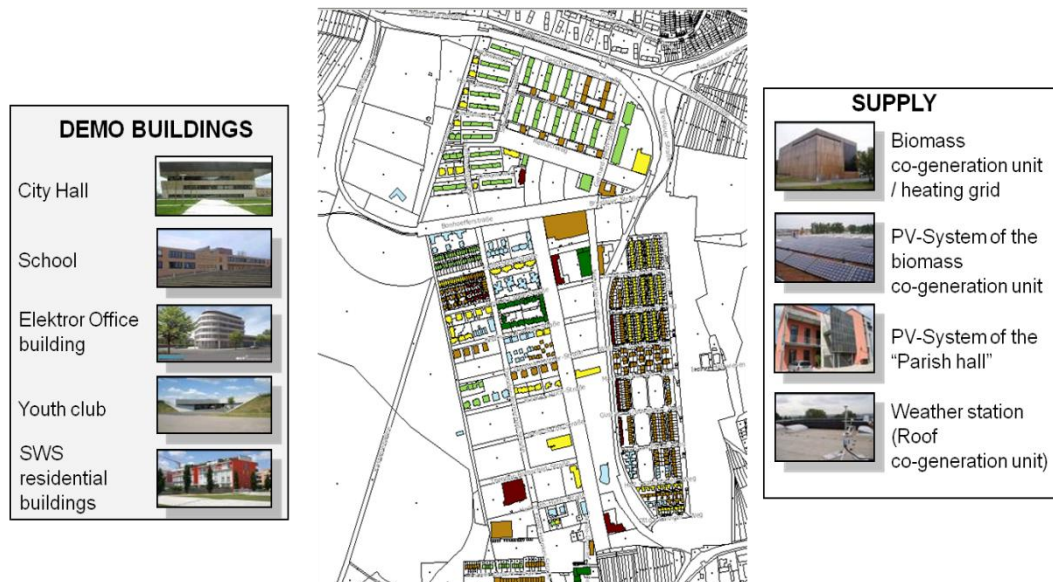

Fig. 1: Design, demonstration buildings and renewable supply of Scharnhäuser Park

1.3 Building energy efficiency targets

When the site was developed, energy standards for buildings were established by the town of Ostfildern in 1995, which demanded 25% lower end energy demand values than the existing national German standard at that time (WSVO 1995) requiring a maximum heating end energy demand values of 70 - 100 kWh m⁻²a⁻¹, depending on the ratio of surface to volume (from 0.5 up to 1.05 or higher).

The targets set in the POLYCITY project for heating energy consumption were kWh m⁻²a⁻¹ for residential buildings and 50 kWh m⁻²a⁻¹ for office buildings, for electricity consumption 28 kWh m⁻²a⁻¹ (residential buildings) and 35 kWh m⁻²a⁻¹ (office buildings). Under German climatic conditions residential buildings are not supposed to have active cooling systems, for office buildings the POLYCITY target was 30 kWh m⁻²a⁻¹ cooling end energy. In summary, the requirements set by the project in 2003 were sufficiently high to fulfil today's much more demanding legislation.

Only a small fraction of residential buildings in the Scharnhäuser Park received additional funding (13216 m² out of a total residential area of 178000 m²). Three four-storey multi-family

apartment buildings of 5540 m² with a total of 42 apartments received 28 €/m² funding for energy measures, which corresponds to less than 3% of the total construction costs of 1065 €/m². A total of 10 single family houses also received 3% funding with total construction costs of 896 €/m². All buildings were planned and constructed by the housing society Siedlungswerk Stuttgart GmbH during 2005 and 2010. The residential building measures supported include higher insulation standards (6 cm higher wall insulation and 4 cm more roof insulation and improved low e-coated double glazing with plastic spacers), low temperature heat distribution systems to reduce the district heating return temperatures (floor heating system) and mechanical exhaust ventilation for good indoor air quality control.

In the office building project of the company Elektror GmbH, low temperature heat and cold distribution systems were chosen (concrete core activation) to improve the performance of the absorption chillers for cooling and to reduce peak power demand. The foundation piles were activated with plastic tubes to extract heat from the ground during winter and to reject heat loads from the ventilation system during summer. To reduce the electricity consumption for lighting, a centrally controlled corridor dimming strategy was chosen combined with highly efficient individual work space lamps, which are dimmed according to daylight availability.

A newly constructed public building of the municipality of Ostfildern was designed for near passive standard. Low-e coated double glazings were used instead of the more expensive triple glazings in passive standard buildings, as the building is used as a youth centre, with high risks of damage of such expensive material.

1.4 Renewable supply systems

Two buildings at the project site are equipped with integrated PV-systems. The biomass power plant and the parking lot of the parish hall building.

In terms of covering the demand for both heating and electricity, an Organic-Rankine-Cycle (ORC) is the most suitable combined heat and power solution in the power range of 500 kW to

2000 kW (electric output).

In 1993 the local supply company Stadtwerke Esslingen (SWE) took over the energy systems of Nellingen Barracks from the US Forces, at that time the network was supplied with steam. The former infrastructure has been taken out of operation and was replaced by a new hot water network. The structure of the heating network was coordinated with the development plan of the road system in this area.

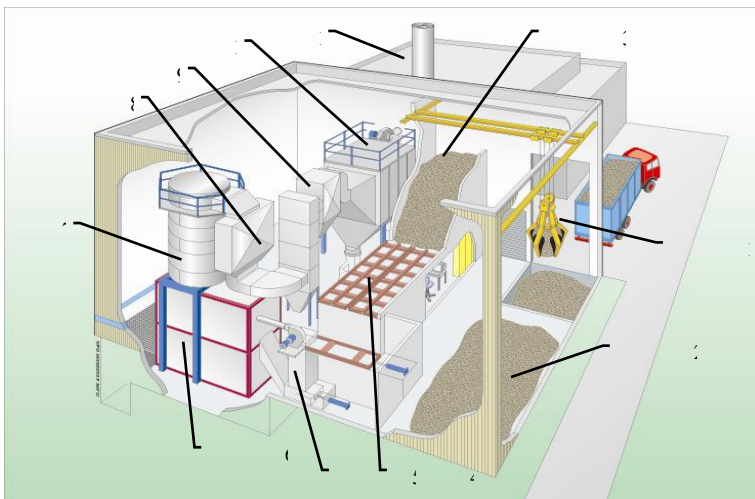

- 1: delivery zone / crane
- 2: long term storage
- 3: short term storage
- 4: moving grate
- 5: stoker
- 6: combustion chamber
- 7: boiler
- 8: economizer
- 9: cyclone
- 10: electrostatic filter
- 11: turbine house (ORC / gas

boilers)

Fig. 2: Section through biomass plant Scharnhäuser Park

Fig. 2 shows a 3D-drawing of the biomass power plant. The storage and the furnace are shown in the front. The building in the background is the turbine house where the gas boilers (5 MW and 9 MW until 2010, then twice 9 MW) are situated as well. The scheme shows delivery zone, furnace and exhaust treatment.

Fig. 3 is a scheme of the cogeneration unit. The thermal energy is fed into the system (left) via a thermal oil system, circulating between the main building and the turbine house.

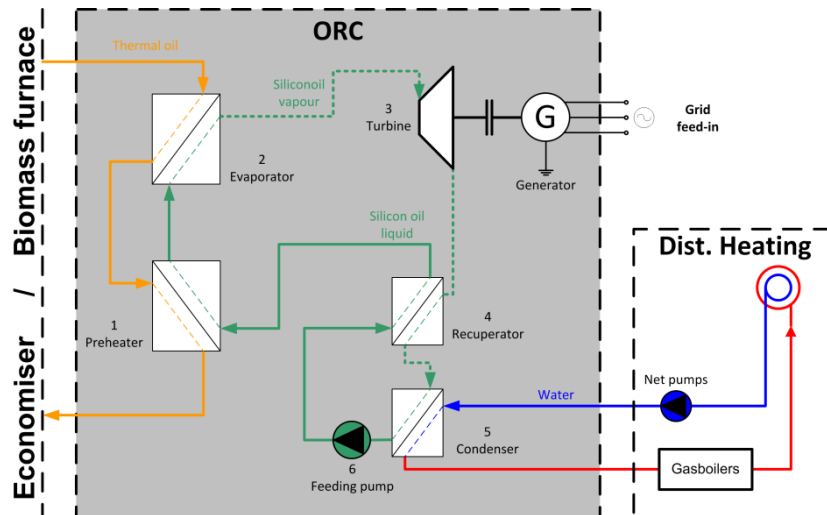

Fig. 3: ORC-scheme including district heating

2. RESULTS BUILDING ENERGY EFFICIENCY

The district heating network supplied by the ORC cogeneration plant provides heating for row houses, public buildings and multi-family houses; the heat distribution can be seen in the Sankey diagram presented in Fig. 4. 16% of all the energy delivered by the cogeneration plant is lost through distribution; 63% of total heating energy is delivered to residential buildings, mainly multi-family buildings and row houses. Other buildings with commercial, educational and administrative functions account for 21% of all the heating energy delivered.

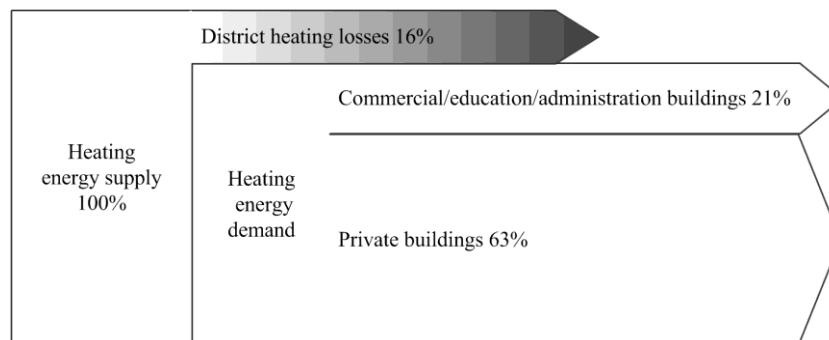

Fig. 4: Distribution of heating energy delivered by the biomass co-generation plant (2009)

The measured consumption of all multi-family houses is in general slightly lower than for the average row houses (between 56 and 68 kWh m⁻²a⁻¹ for the years 2005 and 2009 for multi-family

houses, compared to 62 to 69 kWh m⁻²a⁻¹ for the row houses). All measured annual consumption values were normalized to the gross surface area, which creates some errors, as the gross surface areas were determined using basic geo-information system data (ground floor area and number of floors). Also some consumption metering information included several buildings and the value was equally distributed to the building surfaces. Fig. 5 illustrates the heating energy consumption for all multi-family houses from 2005 to 2009; the extreme ranges (0 to 20 and 100 to 120 kWh/m²a) include a low number of buildings; the majority of buildings are in the ranges 40-60 and 60-80 kWh/m²a, and this last range grew from 2005 to 2009.

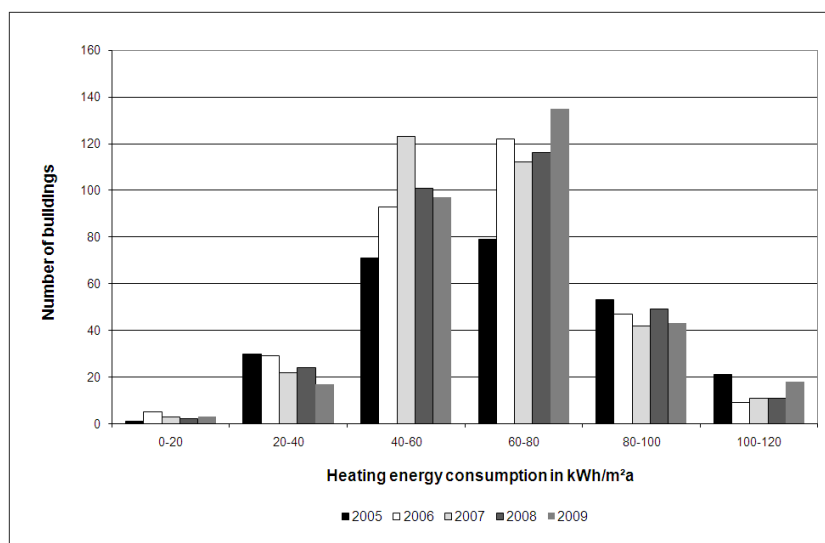

Fig. 5: Distribution of heating energy consumption measured for all multi-family houses

Fig. 5 presents the measured heating and electricity energy consumption per gross surface area of the demonstration project multi-family apartment building of the Siedlungswerk GmbH (SWG). The Siedlungswerk apartment building fulfils the set requirements for heating energy demand well. As can be seen, only in the first year of occupation the measured consumption was higher than specified. Regarding the electricity consumption only the value for the year 2010 is available, which fulfils the set requirement for electricity demand of 28 kWh m⁻²a⁻¹.

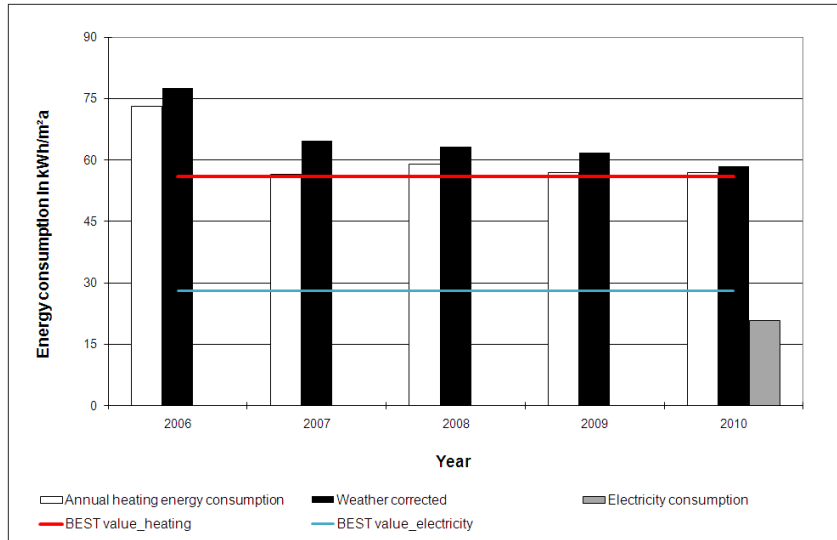

Fig. 6: Measured heating and electricity consumption per gross surface area of the multi-family apartment building of SWG.

Fig. 7 shows that the consumption of individual apartments fluctuates very strongly, showing the high user influence. Large variation in both heating and electrical energy consumption even in nominally similar dwellings have also been observed under UK climatic conditions [12]. Factors such as number of occupants, number and type of appliances, and occupancy patterns are more relevant than the built form [11].

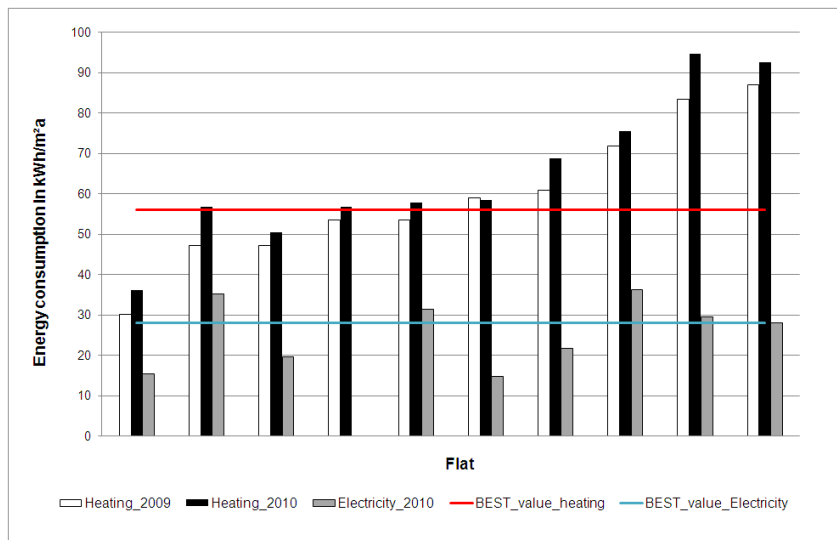

Fig. 7: Annual heating and electricity consumption for individual apartments

The distributions of the annual electricity consumption per gross area and per person for all buildings (multi-family houses and row houses) for the year 2005 are shown in the Fig. 8.

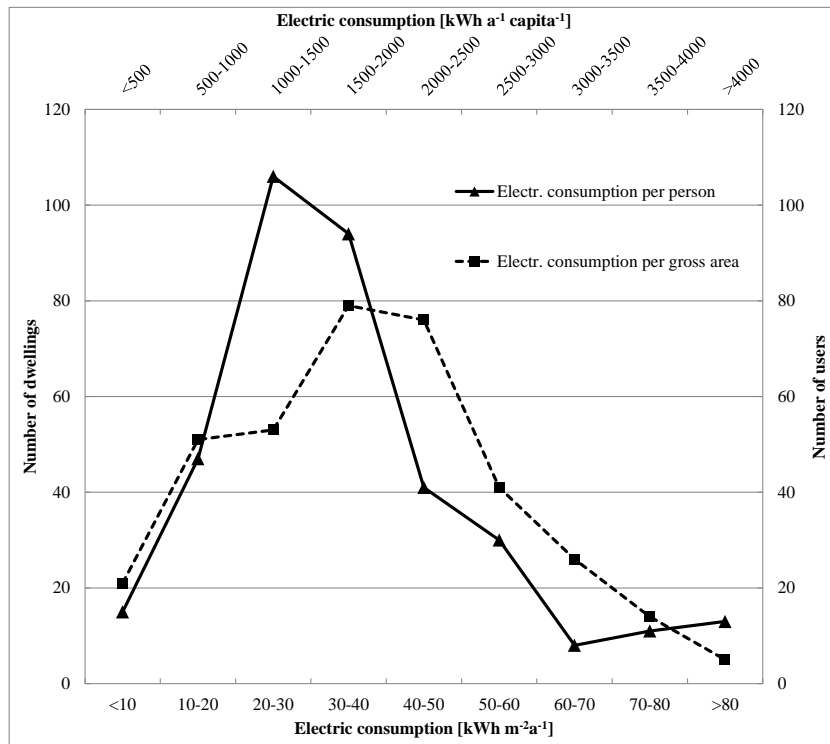

Fig. 8: Annual electricity consumption values for all buildings of SHP

Fig. 9 illustrates the distribution of heating energy consumption for all row houses. The row houses analysed did not receive funding from the POLYCITY project and were constructed by different housing societies or investors. Despite rather similar building type and construction age, the consumption fluctuates strongly.

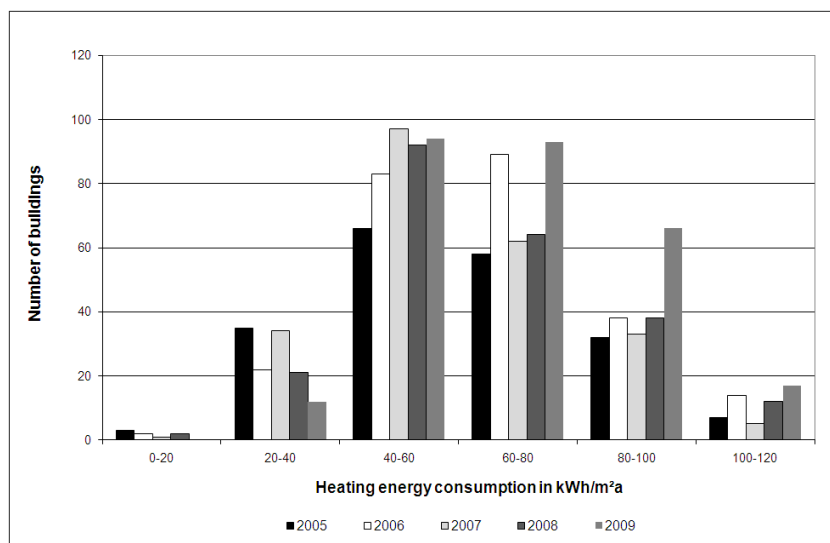

Fig. 9: Distribution of heating energy consumption for all row houses.

For interpreting the high variability and to evaluate the influence of user behaviour, row houses with a very similar construction type were compared. As can be seen in Fig. 10 the calculated demand is very similar for the analysed group of row houses (shown as “Calculation 1”); however, monitoring results showed strong fluctuations of consumption within the same building type, demonstrating again the rather high user influence.

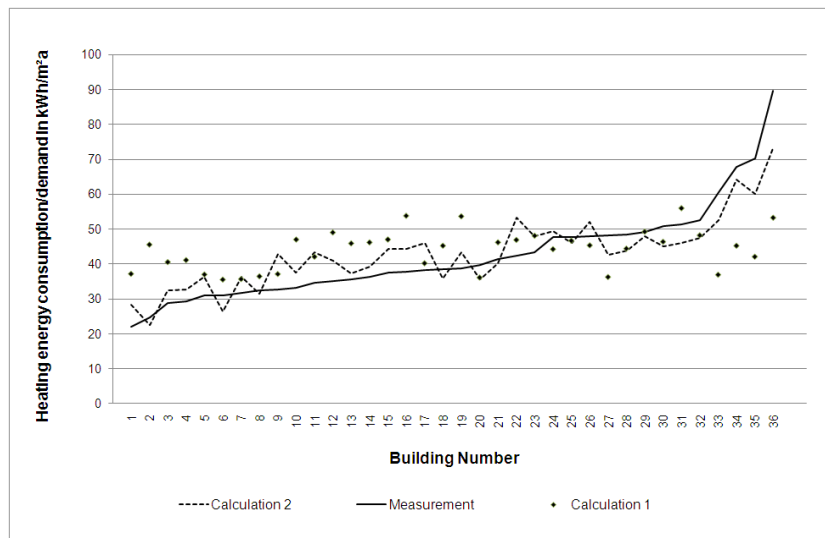

Fig. 10: Measured heating energy consumption compared to calculated demand for similar row house types.

From the 36 houses considered in this analysis, 12 (33%) presented heat energy consumption higher than the calculated demand, and the remaining 24 (67%) had measured values less or equal to the calculated demand. If user related building parameters (air change rates, heating set-point temperatures, night shut-off times of heating system) are statistically varied (shown as “Calculation 2”), the measured consumption curves can be approximated quite well.

3. RESULTS FROM ENERGY SUPPLY SYSTEMS

3.1 PV-generators

At the project site building integrated PV generators have been applied. The main building of the biomass power plant has been equipped with a roof system (99 modules /20.8 kW_p) and a facade system containing 70 modules (10 columns 7 rows/ 14.0 kW_p). Furthermore the parking lot of the parish hall building has a 4.95 kW_p facade generator. Since the year 2006 the grid feed in has been monitored and compared to estimated values derived from a PV-simulation based on weather data.

#	converter	module	roof/facade	serial	parallel	total peak power	
						[-]	[W]
1	SMA WR6KA-03	SunTechnics F210	r	11	3	33	6 930
2	SMA WR6KA-03	SunTechnics F210	r	11	3	33	6 930
3	SMA WR6KA-03	SunTechnics F210	r	11	3	33	6 930
4	SMA WR30-008	SunTechnics F200	f	9	2	18	3 600
5	SMA WR30-008	SunTechnics F200	f	9	2	18	3 600
6	SMA WR30-008	SunTechnics F200	f	9	2	18	3 600
7	SMA WR28i-05	SunTechnics F200	f	8	2	16	3 200
						169	34 790

Tab. 1: specifications of PV-system integrated in power plant building

#	converter	module	roof/facade	serial	parallel	total peak power	
						[-]	[W]
1	SMA SB4200TL	Engcotec 1000-100	f	27	1	27	2 970
2	SMA SB4200TL	Engcotec 1000-101	f	18	1	18	1 980
						45	4 950

Tab. 2: specifications of PV-system integrated in parking lot/parish hall

The Tab. 3 shows the yields of the system at the power plant. The parish hall system performs slightly worse than the power plant system. This is caused by shading due to a large antenna installation of the opposite fire rescue building. In general the results are satisfying for this geographical location.

Year	Facade		Roof		Total
	[kWh/a]	[kWh/kW _p]	[kWh/a]	[kWh/kW _p]	
2006*	8 291	592	19 775	951	28 066
2007	11 435	817	23 320	1 122	34 755
2008	10 205	729	21 642	1 041	31 847
2009	10 969	784	21 539	1 036	32 508
2010	10 099	721	20 024	963	30 123

*since 2006-03-27

Tab. 3: performance of PV systems integrated in power plant building

Taking the measured values and the results of the simulation (20 years) into account the annual yield of the two buildings will be 35200 kWh/a (32000 kWh/a and 3300 kWh/a). Thus about 0.5% of the quarter's electric demand is covered by these two PV installations.

3.2 Cogeneration plant

The ORC cogeneration plant was constructed in Scharnhauser Park considering the adequateness of such systems to the sustainable city quarter's demand profile. Co-generation is a rational (and sustainable) way of using energy, since it reduces the use of electric energy from the national grid (often produced by burning fossil fuels). The ratio of waste heat from the OR-cycle's condenser and the converted electric energy are suitable regarding climate conditions, building standard and user demand conditions. In this plant biomass harvested in the region (which saves energy for transportation) is burnt in a furnace. Tab. 4 presents the design specifications of the biomass furnace; Fig. 3 illustrates the ORC cogeneration plant with district heating system; the thermal power from biomass into the network is 5.3 MW and electric power delivered to the electric grid is 1 MW.

Aggregate	Description	Value	Unit	Reference
Biomass furnace	thermal power (max)	8 000	kW	Manufacturer
Wood storage	capacity	1 400	m ³	Manufacturer
Fuel consumption	design point	200	m ³ /d	Manufacturer
Auxiliary power furnace	electric in / thermal out	25	kWh _{el} /MWh _{th}	Manufacturer
Annual wood consumption	average	43 000	t/a	SWE
Fossil fuel saving		38 000	MWh/a	SWE
CO ₂ -reduction		7 000	t/a	SWE

Tab. 4: Design specifications of the biomass furnace

Tab. 5 shows an overview of the cogeneration unit's specifications. Electrical losses consist of power for the feeding-pump, the alternator cooling system and radiation losses. Thermal losses are mainly caused by radiation.

Technical specifications ORC			
Thermal input		6 356	kW
Electrical output (net)		950	kVA
Thermal output (condenser)		5 300	kW
Electrical efficiency (@100%)		0.15	
Thermal efficiency		0.78	
Electrical and thermal losses		156	kW

Tab. 5: Design specifications of the ORC [GET]

During normal operation, the biomass supplies 80% of the total heating energy demand. Only in 2009 there was a long plant shutdown due to a fire incidence, causing a huge deviation. Since then the plant is running at a reduced maximum power level; the auxiliary natural gas boilers were then started up for meeting the heating network demand.

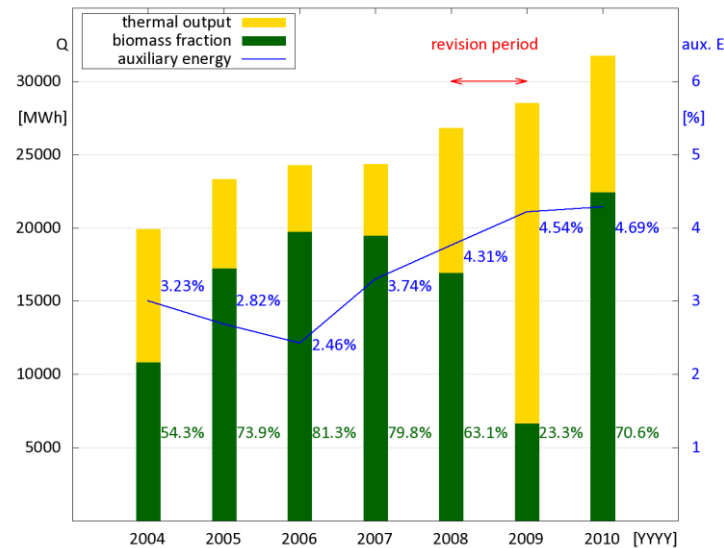

Fig. 11: Development of biomass fraction of total heat demand incl. aux. energy

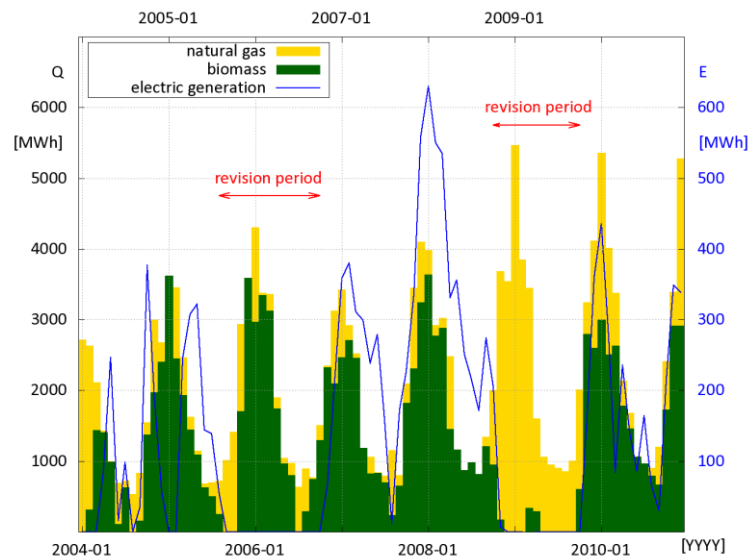

Fig. 12: Monthly demand and biomass coverage and electric yield

Over a period of seven years, all auxiliary supply of the biomass plant has been monitored. In addition to the thermal conversion efficiency, the auxiliary electric energy consumption for biomass ventilation fans, thermo-oil pumps etc. has been measured and related to the total thermal energy produced. For the conversion of biomass to district heat, 36.6 kWh (average) electric energy for the combustion process per MWh of thermal energy are necessary (Fig. 11). Including the heat from gas boilers, with lower auxiliary electricity demand this value decrease to 33.6 kWh_{el}/MWh_{th}. Taking into account all converted energy in the plan, including the electricity and dissipated heat by

excess cooling, the overall electric demand sums up to 23.35 kWh_{el}/MWh_{th}.

As the ORC-module had low operation hours and often runs in part load conditions, the own auxiliary consumption of electricity of the whole plant including the combustion process is high. In total the own electricity consumption compared to the electric energy fed to the grid was 28.2% in 2007 (939 MWh out of 3327 MWh electricity feed in) and 29.6% in 2008 (1044 MWh out of 3527 MWh).

The electric gross efficiency of the ORC module was expected to be around 16.4%. So far, the mean annual efficiency is 8.9 % (seven years) and maximum values of 15.5% in the upper load range (5.5 MW - 6.3 MW) have been reached (Fig. 14). The so far best year was 2008, with an average efficiency of 14.5%, the worst 2006 (1.6%). The large number of down-times and the unexpectedly low demand for heating energy forced part-load operation.

Despite the enormous advantages concerning CO₂ and primary energy saving the success of biomass facilities is very much depending on the annual load distribution. High building standard housing such as in Scharnhauser Park reduce the demand for heat. Also in summer only very low loads for warm water have to be covered. This leads to several economical and technical challenges. To keep the ORC module operational, a minimum heating power (2 MW to 3 MW) needs to be transferred. Additionally the cooling system of the alternator, which is connected to the network, is limited to 85°C in partial load. Thus even short time peaks have to be compensated by re-cooling. Low loads of 1 MW during summer are common. In these cases 1 to 2 MW of heating power are rejected to the environment by the re-cooler. An alternative to heat rejection is the use of thermal cooling systems during summer.

The overall feed-in tariff according to the German Grid-Access-Act can be up to 0.22 €/kWh, using sustainable fuel and a new technology for conversion. Economic studies [28] assume a project feasibility with a compensation of 0.1 €/kWh to 0.14 €/kWh for a unit size of 1 MW to 1.5 MW.

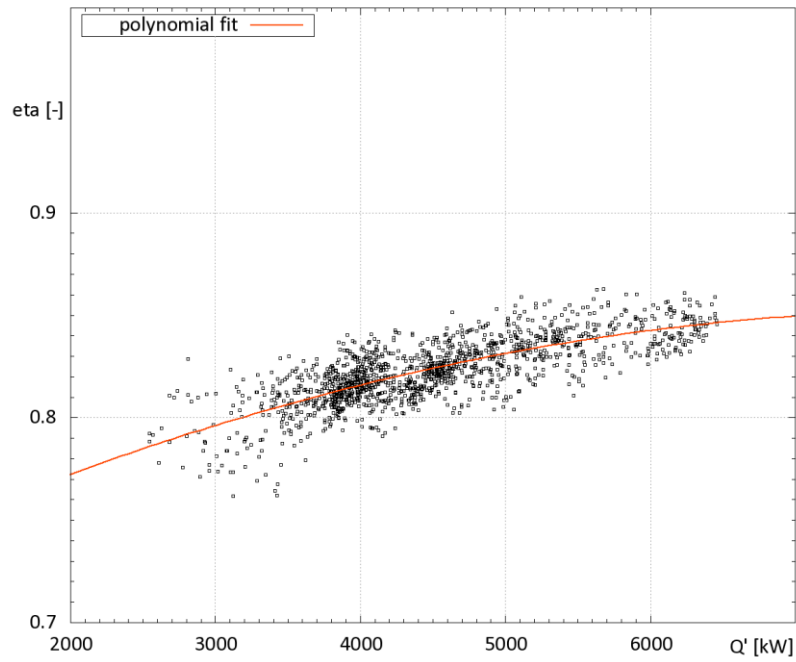

Fig. 13: Measured combustion efficiency versus thermal output

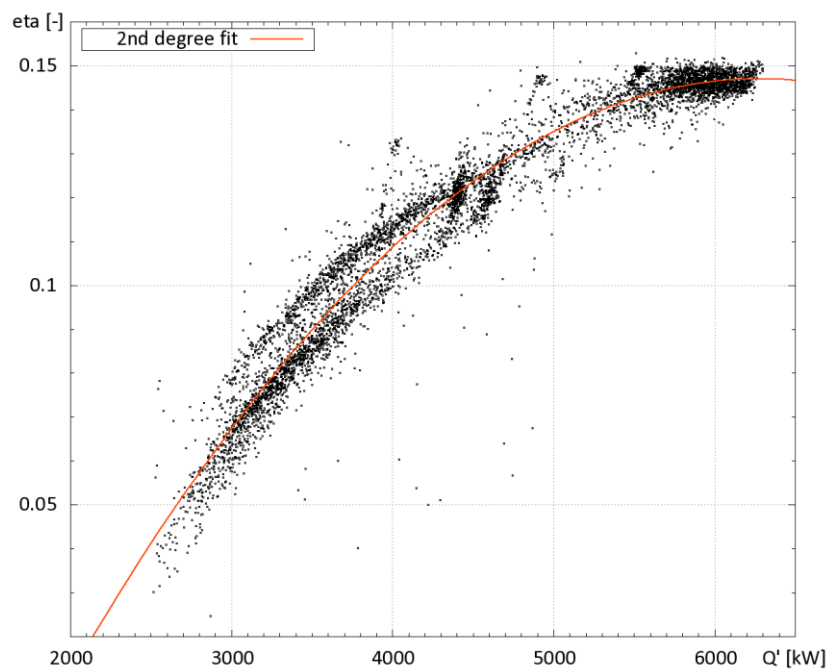

Fig. 14: Measured electric efficiency versus thermal input

A simulated characteristic of the OR-cycle's efficiency is shown in Fig. 14. With lower condenser temperatures the efficiency should rise. This curve has been derived from the technical specifications for a similar sized module of the company of Turboden [25]. Organic-Rankine processes are expected to function at high efficiency over a wide load range [7]. In practical

application both temperature levels and mass-flows alter with load conditions. In a part-load situation a heat guided cycle works with lower heat input and output, mainly regulated by lower mass flows, which decreases the heat transfer coefficients.

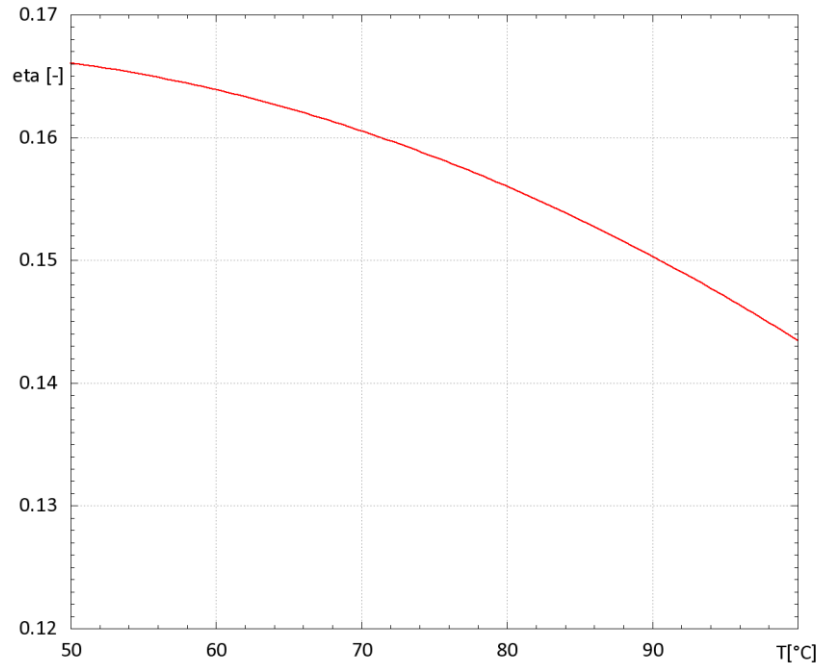

Fig. 15: Expected ORC load behaviour versus sink temperature, calculated

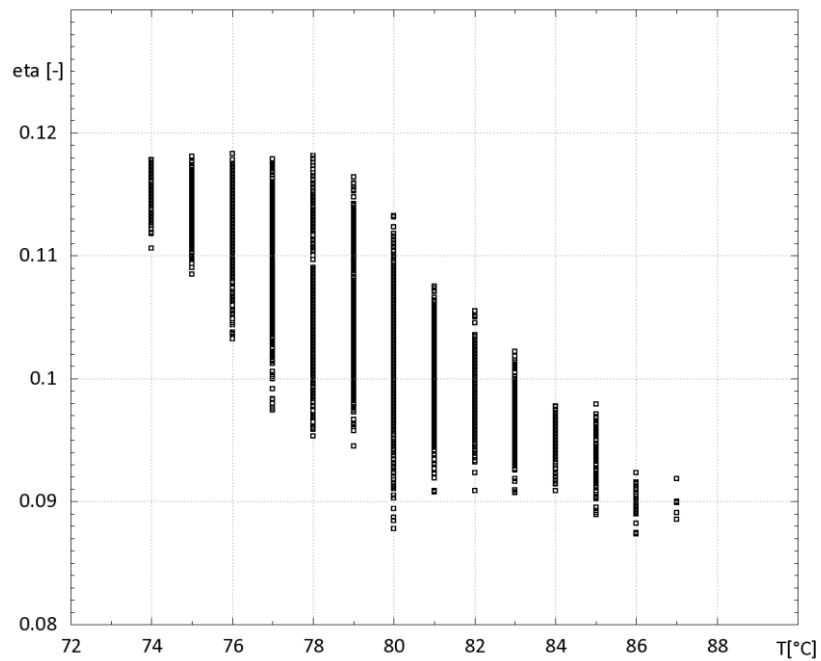

Fig. 16: ORC load behaviour sink temperature, measured

The furnace provides optimal efficiencies in a range of 5 MW to 6.5 MW, as shown in Fig. 13.

The Cogeneration system provides its best performance according to Fig. 14 in a load range of 5.5 MW to 6.3 MW of thermal input. Combining these load states with a network feeding temperature of 74°C to 78°C, as shown in Fig. 16, provides the best operation conditions for the ORC.

3.1 Decentralised absorption cooling

The Elektror company office building, with an office surface area of 3.280 m², is heated and cooled using the heat from the biomass ORC cogeneration plant. Winter heating energy is supplied to thermally activated ceilings in addition to convectors at the air outlets. Cooling is only provided to the concrete core ceiling. The installed absorption chiller with 105 kW cooling power is directly connected to the district heating network and provides about 2/3 of the total cooling energy demand of the building (180 MWh per year); approximately 50% of the low summer district heating hot water flow is necessary for driving the absorption chiller. Fig. 17 illustrates the contribution of absorption and back up compression chillers in the building for the monitored period.

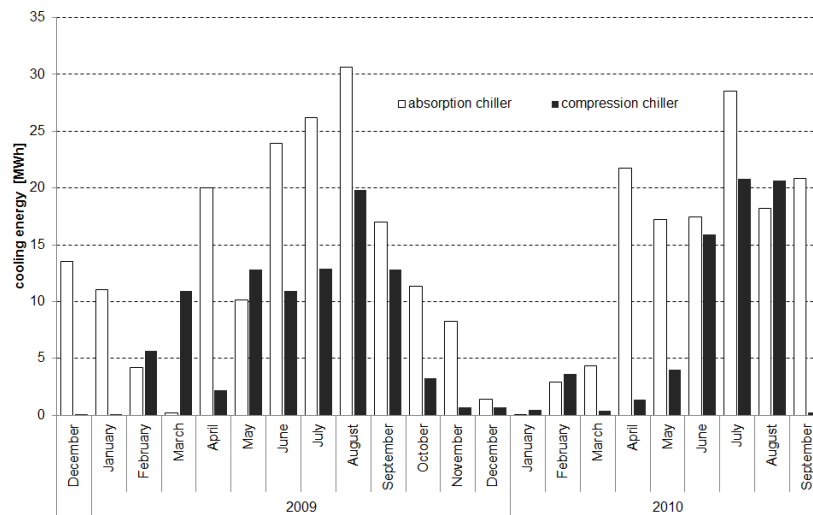

Fig. 17: Cooling energy provided to the office building by absorption and compression chillers.

The coefficient of performance of the chiller was between 0.6 and 0.7 during summer months and thus corresponds to expectations; its variation for the monitored period is presented in Fig. 18. The performance drop during autumn and winter months can be attributed to frequent switch-on and

off under part load conditions and needs to be optimised during the next months. The annual heating energy required for the absorption chiller (371 MWh of heating in 2009) is similar to the winter heating energy demand (320 MWh heat for cooling in 2009) and this helps to increase operation hours of the ORC plant in summer.

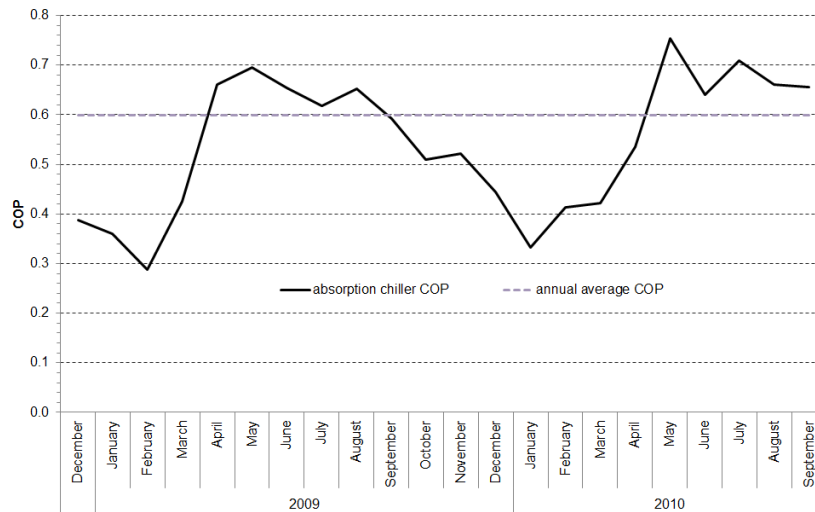

Fig. 18: Coefficient of performance of the absorption chiller in the Elektror office building.

4. POTENTIAL FOR REPLICATION

The POLYCITY project was developed considering the application of low energy building standards, use of renewable energy (photovoltaic panels and biomass ORC cogeneration cycle) and absorption cooling driven by the heating network system. The project results are impressive and its potential of replication for other cities can now be evaluated; as Brazil has nowadays a regulatory framework open to these initiatives, an evaluation of the replication potential of such technologies is appropriate. The relationship between the POLYCITY project and the Brazilian regulatory framework are in terms of energy efficiency measures, use of renewable energy/sources and cogeneration.

There is no similar experience to the POLYCITY project in Brazil; the urban planning associated to the city of Curitiba is the Brazilian best experience and is devoted to the creation of parks, recycling programs and transportation solutions. The construction and analysis of thermal

behavior of small houses under on-site conditions are developed by several groups in universities and research centers [18, 19].

Despite the relevance of considering energy efficiency practices for buildings, it was not a reality until the advent of the new regulatory framework that is, however, still voluntary for commercial, tertiary and public buildings. Commercial and public buildings were previously contemplated in the energy efficiency program of the electric sector (Procel, in Portuguese), which contains a special program for buildings (Procel Edifica).

Because of this program, some individual building monitoring results are available; however, data relative to sustainable city quarters and electric consumption of buildings in Brazil is scarce [13].

However, Brazil faces a multifaceted reality. Another study [22] analysed the conditions of social housing in Rio de Janeiro and pointed out the financial limitation for applying some technologies in this niche of construction.. The major barrier is economic due to the Brazilian social reality, in which some 80 million inhabitants have access to goods and services in a standard very similar to the one experienced by western European or other industrialized countries and over 100 million inhabitants are in a difficult social and economic situation [17].

Residential building measures implemented in POLYCITY project, like higher insulation standards, efficient heating/cooling distribution systems and mechanical exhaust ventilation, can also be attractive for other countries. This is especially true for commercial and public buildings, but also must be considered in the residential sector where income limitation is not a serious constraint. The use of concrete core activation technology in commercial buildings is another possible technique to be considered in the buildings construction for low temperature heat and high temperature cold distribution. Furthermore, ground heat exchange would be useful for extracting heat during winter and to reject heat loads during summer.

Network based heating and cooling distribution solutions are another special technology of

POLYCITY project that might be considered in the Brazilian context. By using a cogeneration system, the heat rejected by the thermal cycle may be distributed in a network for space heating. Given the climatic conditions of Brazil, the Southern and Southeast states have lower temperatures in winter and can benefit from the use of heat distribution. Once more, the commercial and public buildings, and residential buildings that voluntarily apply for the Brazilian labelling system, have the chance of evaluating the technical and economic attractiveness of implementing such systems.

The major energy demand for thermal comfort in Brazil is caused by electricity for cooling. In the great majority, self-contained and split-type air conditioning systems are used; central water chiller feeding fan-coil air conditioning systems are generally restricted to office buildings. With the advent of the new regulatory framework, cogeneration systems and absorption chillers (driven by solar heating or the cogenerated rejected heat) will certainly be newly considered. The definition of the technology to be used in each building depends on the demanded electric to cooling ratio, availability and logistics of renewable sources, electricity to fuel prices ratio, among others.

Absorption chillers are frequently suggested in projects, but the implementation depends largely on the economic return period, generally greater than it is obtained for compression systems; in the last decade, several public and private initiatives of integrating absorption units to natural gas combustion engine cogeneration systems were implemented in Brazil, especially in airports and shopping centres [30]. For commercial and public buildings the use of combustion engine burning natural gas or biodiesel certainly presents less constraint in terms of availability/logistics of fuel supply and use of space if compared to ORC technology.

ORC seems to be attractive for little and medium cities, technological parks and horizontal condominiums especially for the convenience of burning biomass. Horizontal condominiums are composed of houses and/or buildings constructed in a space closed off to the general public, composed with ample leisure areas, supermarkets, bakeries and other services; this concept, generally known as "mini-city", is increasing in the same proportion of the safety demand.

Guaratinguetá is a city of 116 thousand inhabitants located in São Paulo State, Brazil, distributed in the urban and rural area; some of the districts are far away downtown and the replication of the POLYCITY project concepts could be considered. Some preliminary studies evaluated that distributed generation could be applied in the micro planning for taking into account economic, energetic and environmental policies for Guaratinguetá [31]; landfilling of municipal solid wastes with production of biogas for electric generation was one of the proposed solutions. The use of municipal solid wastes incineration, associated to efficient combined cycles, were also considered as a way to produce electricity and steam to one of industrial centers of Guaratinguetá [20, 21].

The potential use of ORC in one of the districts of Guaratinguetá, a technological alternative not yet evaluated in the cited studies, can be considered due to the availability of biomass in the rural area and also as a refuse in some industries; some of these industries are evaluating the attractiveness of cogeneration for their electrical and heating needs, and this may be the drive force for starting this process. In addition, the waste heat of an ORC unit may be considered for cooling the industries' office buildings in summer by driving absorption chillers, as in the POLYCITY Elektror office building or integrated to solar-driven considering the favourable solar radiation of tropical countries. In addition, brackish water reverse osmosis units integrated to the ORC unit can also be conceived for polygeneration systems (electricity, cooling and freshwater production).

For a consistent development of cogeneration systems for heating and cooling in buildings, it is important to take into account that this will probably occur only in the medium term (up to 5 years). In addition to the voluntary labelling system, financial incentives (such as long-term loans at attractive interest rates and attractive prices for renewable cogenerated energy) must be implemented and barriers must be surpassed (such as difficulties of feeding the surplus power to the grid in certain concessionaries).

5. CONCLUSIONS

Monitoring of the city quarter Scharnhauser Park in the German city of Ostfildern showed that low energy building standards can be reached on a city neighbourhood scale. The user behaviour leads to a large fluctuation of consumption values, although building age and standard are rather comparable. The monitored multi-family houses had about 10-20% lower energy consumption values than the standard constructions in the area.

The area is supplied with a very high renewable energy fraction of 80% of the heat and 50% of the electricity consumption. The auxiliary electricity consumption of the ORC power plant is rather high, as full load conditions are rarely reached. The situation will be improved with increasing population and with additional heat use in summer, for example from thermal cooling plants in office buildings. A first project was implemented and monitored in one of the offices of the commercial district. The heating energy required for cooling was comparable to the winter heating energy of the building and extends the power plant full load operation during summer during 50 hours approximately.

Replication conditions are possible, as presented; technologically it is feasible to implement each of the considered technologies, adapting them to the climatic and behavioural conditions. Introducing monitoring systems for building energy use is the first step to create data transparency and evaluate building efficiency measures. The strong user influence both on heating and electricity consumption measured in the German case study shows that further communication efforts are required to enable the user to operate the buildings correctly.

Biomass cogeneration with district heating networks can be easily transferred to climates with winter heating demand. In cooling dominated climates, the use of central or decentral absorption chillers with renewable cogeneration plants is a very interesting option. The surpassing of several institutional and economic barriers is the major question to be taken into account in the near future.

ACKNOWLEDGMENTS

The work was funded by the European POLYCITY project (TREN/05FP6EN/S07.43964/513481).

Special thanks to Martin Huber from zafh.net Stuttgart for his help by the automated transfer of the heating energy consumption data via M-Bus data logger. Thanks to Andreas Trinkle and Eric Duminil from zafh.net Stuttgart) for great support in the analysis and data communication. Many thanks to Stadtwerke Esslingen for a great collaboration.

Jose Antonio Perrella Balestieri is indebted to Univ Estadual Paulista for granting him for a research stage and to Hochschule für Technik Stuttgart for providing all the necessary resources for that; he is also indebted to CNPq for a research grant (process 300741/2008-1)

REFERENCES

Journals

1. Newman, P.W.G., Domestic Energy Use in Australian Cities, *Urban Ecology*, Vol. 7, 1982, pp. 19-38
2. Pachauri, S., An analysis of cross-sectional variations in total household energy requirements in India using micro survey data, *Energy Policy*, Vol. 32, 2004, pp. 1723-1735.
3. Schipper, L., International comparisons of energy end use: benefits and risks, *Encycl Energy* 2004, Vol. 3, pp. 529-555
4. Yoshiyuki, Shimoda, Takahiro, Asahi, Ayako, Taniguchi, Minoru, Mizuno, Evaluation of city-scale impact of residential energy conservation measures using the detailed end-use simulation model, *Energy* 32, 2007, pp. 1617–1633
5. Weisz, H., Steinberger, J.K., Reducing energy and material flows in cities, *Current Opinion in Environmental Sustainability*, Vol. 2, 2010, pp. 185–192
6. ANEEL. – Agência Nacional de Energia Elétrica. Requirements for qualifying cogeneration

power plants (Resolucao 235) (in Portuguese). 2006 Available in: <http://www.aneel.gov.br/cedoc/ren2006235.pdf>

7. Obernberger, A., Hammerschmid, R., , Biomasse-Kraft-Wärme-Kopplungen auf Basis des ORC-Prozesses, EU-Thermie-Projekt Admont (A), Bini, VDI-Bericht 1588, 2001
8. Kaltschmitt, M., Hartmann, H., Energie aus Biomasse, Grundlagen, Techniken und Verfahren, Springer, 2009, ISBN 978-3540850946
9. Good, et al., Determination of the Efficiencies of Automatic Biomass Combustion Plants, IEA Report, 2006
10. Juodis, E., Jaraminiene, E., Dudkiewicz, E, Inherent variability of heat consumption in residential buildings, Energy and Buildings, Vol. 41, 2009, pp. 1188-1194
11. Firth, S., Lomas, K., Wright, A., Wall, R., Identifying trends in the use of domestic appliances from household electricity consumption measurements, Energy and Buildings, Vol. 40, 2008, pp. 926-936
12. Lomas, K., Energy use in Dwellings Decarbonising the Stock, and People, Public policy seminar brief ESRC/TSB Seminar, RIBA, 2009
13. Carvalho, M.M.Q.; La Rovere, E.L.; Gonçalves, A.C.M. Analysis of variables that influence electric energy consumption in commercial buildings in Brazil. Renewable and Sustainable Energy Reviews, vol. 14, 2010, p. 3199–3205,
14. Li, B.; Yao, R. Urbanisation and its impact on building energy consumption and efficiency in China. Renewable Energy, vol. 34 , 2009, p. 1994-1998
15. Li, J.; Colombier, M. Managing carbon emissions in China through building energy efficiency. Journal of Environmental Management, vol. 90, 2009, p. 2436-2447
16. Yang, Y.; Li, B.; Yao, R. A method of identifying and weighting indicators of energy

efficiency assessment in Chinese residential buildings. *Energy Policy*, vol. 38, 2010, p. 7687-7697

17. R  ther, R.; Zilles, R., Making the case for grid-connected photovoltaics in Brazil. *Energy Policy*, 2011, doi:10.1016/j.enpol.2010.12.021.
18. Grigoletti, G.; Sattler, M.A.; Morello, A. Analysis of the thermal behaviour of a low cost, single-family, more sustainable house in Porto Alegre, Brazil. *Energy and Buildings*, vol. 40, 2008, p. 1961-1971
19. Carlo, J.; Lamberts, R. Development of envelope efficiency labels for commercial buildings: Effect of different variables on electricity consumption. *Energy and Buildings*, vol. 40, 2008, p. 2002-2008
20. Holanda, M.R., Balestieri, J.A.P., Optimisation of environmental gas cleaning routes for solid wastes cogeneration systems Part I - Analysis of waste incineration steam cycle. *Energy Conversion and Management*, vol. 49, 2008, pp. 791-803
21. Holanda, M.R., Balestieri, J.A.P., Optimisation of environmental gas cleaning routes for solid wastes cogeneration systems - Part II - Analysis of waste incineration combined gas/steam cycle. *Energy Conversion and Management*, vol. 49, 2008, pp. 804-811
22. Bodach, S.; Hamhaber, J. Energy efficiency in social housing: opportunities and barriers from a case study in Brazil, *Energy Policy*, vol. 38, 2010, p. 7898-7910.

Standards, Guidelines and Reports:

23. MME – Minist  rio de Minas e Energia. National plan of energy efficiency (in Portuguese). 2010. Available in: <http://www.mme.gov.br/mme/noticias/destaque1/destaque_150.html>
24. CD – C  mara dos Deputados. Project of Law 630, create special funds for financing research and fomentation of electric and thermal energy production by using solar and wind sources (in

Portuguese). 2009. Available in: < <http://www.camara.gov.br/sileg/integras/674085.pdf>

25. References of Turboden, Turboden s.r.l. Via Cernaia 10, 25124 Brescia - Italy
26. INMETRO – Instituto Nacional de Metrologia, Normalizacao e Qualidade Industrial. Technical requirements of quality for energy efficiency of commercial, services and public buildings - Portaria 372 (in Portuguese). 2010. Available in: <<http://www.inmetro.gov.br/legislacao/rtac/pdf/RTAC001599.pdf>>
27. Technical Report 07A03061e, List of Recent Projects, Turboden Srl, 31.05.2008, Brescia, Italy.
28. Duvia, A., Technical and economic aspects of Biomass fuelled CHP plants based on ORC turbo generators feeding existing district heating networks, 2009
29. Eicker, U., Strzalka, A., Erhart, T., Energy efficient buildings and renewable supply within the German POLYCITY project, Proceedings of the POLYCITY final conference, Stuttgart, 2010.
30. Cogenrio (Rio de Janeiro cogeneration association), list of cogeneration cases (in Portuguese). Available in: < <http://www.cogenrio.com.br/Prod/Casos.aspx>>. 03/03/2011.

Dissertations

31. Sampaio, H.C., Planning and optimization of energy systems for economic and environmental management of cities (in Portuguese). PhD Thesis (Mechanical Engineering), Univ Estadual Paulista, Guaratinguetá, Brazil, 2007

Biography

U. Eicker (*1963), physicist, professor. Carries out international research projects on solar cooling, heating, electricity production and building energy efficiency at the University of Applied Sciences in Stuttgart since 1993. Since 2002 she is the scientific director of the research centre sustainable energy technologies (zafh.net) in Baden Württemberg. She also heads the Institute of Applied Research of the University of Applied Sciences in Stuttgart, where building physicists, geoinformation scientists, mathematicians, civil engineers and architects cooperate. During the last ten years she coordinated numerous research projects on sustainable energy plants and buildings. Currently Prof. Eicker is the coordinator of an integrated European project POLYCITY on sustainable communities with 18 partners and a total budget of 17 million Euros.

A. Strzalka (*1979) graduated the Master Course “Sustainable Energy Competence” in April 2005 from the University of Applied Sciences in Stuttgart. Since 2005 Aneta Strzalka is working on the project POLYCITY. Since 2006 Aneta Strzalka is also a PhD-Student supervised by Prof. Ursula Eicker (Stuttgart University of Applied Sciences) and Prof. R. Ulbrich (Faculty of Mechanical Engineering at Opole University of Technology).

T. Erhart (*1979) graduated 2007 from Master Course “Sustainable Energy Competence”, working in POLYCITY project until 2010. Since 2010 working in EU-project “RecoORC”. PhD-Student at Strathclyde University of Glasgow under supervision of Prof. D. Infield and Prof. U. Eicker.

José A. Perrella Balestieri (*1963), mechanical engineer, is a professor of Univ Estadual Paulista (UNESP) since 1989 and researcher of The National Council for Scientific and Technological Development (CNPq). His main research topics are; energy planning; energy efficiency; polygeneraion; optimization models